

## Preface

Thank you very much for choosing the products of Weichai New Energy Commercial Vehicle Co. Ltd. Before you use the vehicle, please carefully read the Operation Manual of this vehicle to ensure that you are familiar with the

structure and technical characteristics of Weichai New Energy Commercial Vehicle Diesel Mini Truck Series products, master the correct methods of vehicle use, maintenance and repair, and abide by the correct operation instructions of the vehicle in this Manual, focusing on the clauses and contents marked with **attentions, warnings, dangers**, etc. that may cause injuries to the vehicle or personnel. Damage to the vehicle caused by violation of operating instructions is not covered by the warranty of the vehicle.

When reading this Manual, please pay attention to the following matters:

All information contained in this Manual is based on the latest information at present, but with the progress and development of technology, our products will be continuously improved and perfected. We reserve the right to change the design and specifications of this Manual at any time, and do not undertake the obligation to install the additions and changes to the previously manufactured products.

This instruction manual is applicable to the export products of Weichai New Energy Commercial Vehicle Diesel Air Brake Series. Due to the different configurations of different models, not all vehicles are equipped with some devices or functions introduced in it, and some instructions (including those related to display and menu functions) may not be applicable to the models you purchased.

In order to avoid causing damage to vehicle devices and even causing safety accidents, it is strictly forbidden for users to modify or install equipment without authorization, especially for electrical appliances, braking, steering, after-treatment and other systems related to driving safety.

When replacing parts, please go to Weichai New Energy Commercial Vehicle Special Repair Station to purchase and use genuine parts provided by our company.

When you buy the vehicle, please don't forget to ask for and properly keep all the accompanying information; please come with this vehicle when reselling it.

After carefully reading this Manual, if you have any questions, you can go to Weichai New Energy Commercial Vehicle Special Repair Station or consult Weichai New Energy Commercial Vehicle Customer Service Center, and we will provide you with warm and perfect service.

## Instructions to Users

1. When you buy the vehicle, please check whether the accompanying technical documents are complete.
2. Please read this Manual carefully before using the vehicle.
3. Please go to the Special Repair Station of our company for running-in maintenance and regular maintenance according to the specified mileage or time limit, otherwise it will be regarded as your automatic waiver of warranty rights.
4. If your vehicle breaks down within the specified quality warranty period, please go to the Special Repair Station of our company for maintenance with the *Product Warranty Manual*. If the vehicle breaks down due to product quality, our company will be responsible for free warranty; fault due to non-product quality reasons, and vehicles repaired by ourselves without our consent or entrusted by non-Special Repair Station of our company after fault, our company will not guarantee.
5. Please fill the fuel that meets the requirements of engine standards, otherwise the engine fuel supply system and vehicle after-treatment system will be damaged.
6. Tire inflation pressure must meet the requirements of tire inflation pressure in the Manual.
7. When replacing parts of vehicles, please use genuine parts of Weichai New Energy Commercial Vehicle to ensure maintenance quality and prevent potential safety hazards or damage to vehicles due to the use of fake and inferior parts. Our company will not guarantee the vehicle fault caused by the use of non-Weichai New Energy Commercial Vehicle Genuine Accessories.
8. Our company will not guarantee the fault or damage to the vehicle caused by failing to use and maintain the vehicle according to the requirements specified in this Manual, overloading or unauthorized modification of the vehicle or equipment.
9. Environmental hazardous wastes, such as batteries and engine oil, must be treated in an environmentally friendly and safe way. When you are unsure what type of waste can be discarded,

please consult the Special Repair Station or Customer Service Center.

10. Recycling: almost the vehicle can be recycled. Therefore, we ask the last owner of this vehicle to contact the distributor and ask him to recommend a certified/licensed resource recycling agency.
11. If you encounter difficulties or ambiguity in the process of vehicle use, repair and maintenance, please contact our Customer Service Center in time.

Instructions to Users .....	3
Important matters .....	6
Location of VIN and engine number .....	6
<b>Running-in of new vehicle</b> .....	7
<b>Operation and management of vehicles</b> .....	8
<b>Cab turnover mechanism</b> .....	10
<b>Control device and instrument</b> .....	14
<b>Instrument panel</b> .....	14
<b>Instrument and indicator</b> .....	17
<b>Control device</b> .....	68
<b>Steering wheel and horn button</b> .....	68
<b>Cruise control function</b> .....	69
<b>Audio control function</b> .....	70
Ignition switch.....	72
Combination switch.....	73
<b>Light control switch</b> .....	74
<b>EPB combination switch (some models)</b> .....	83
External lights.....	110
<b>Before driving</b> .....	149
Operation of various controllers.....	149

List of daily inspection of drivers .....	164
<b>Driving operation</b> .....	171
Preparation before engine starting .....	171
Exhaust gas treatment device.....	174
Parking (some models) .....	183
Driving on ice and snow .....	190
In an emergency.....	191
Traction of air-cut brake vehicle.....	194
<b>Repair and maintenance</b> .....	213
Maintenance guide.....	227
Recommended grades of lubricating grease and fuel .....	285
Lubrication position figure .....	289
Guide to lubrication .....	290
Loading method .....	297
Loading method.....	297
<b>Main data and specifications</b> .....	304
<b>Instructions on the measurement of vehicle overall dimensions</b> .....	310

## Important matters

### Location of VIN and engine number

#### Location of VIN and engine number

Please write down the vehicle identification code (VIN) and engine number, so as to provide them to Weichai New Energy Commercial Vehicle distributor or Special Repair Station when repairing and maintaining the vehicle.

(VIN)

#### Location of vehicle identification number (VIN)

The VIN code of this series of trucks and chassis has been written into the engine ECU.

VIN code reading in ECU: read through Weichai DiagSmart or Bosch KT660.

ECU reading VIN code method: the key is in the ON position, and the reading tool is connected to the OBD interface of the vehicle to read VIN code. The steel stamp number of the VIN code is located outside the rear end of the right longitudinal beam of the frame or outside the left longitudinal beam of the upper frame.

Vehicle nameplate: pasted on the right side of cab, lower end of door lock, 10 mm outside the edge of door inner panel.

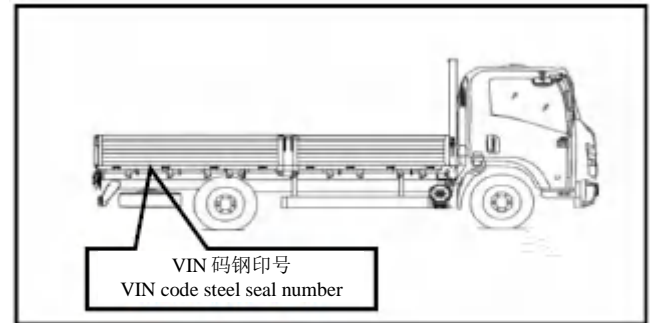

#### Position of engine number

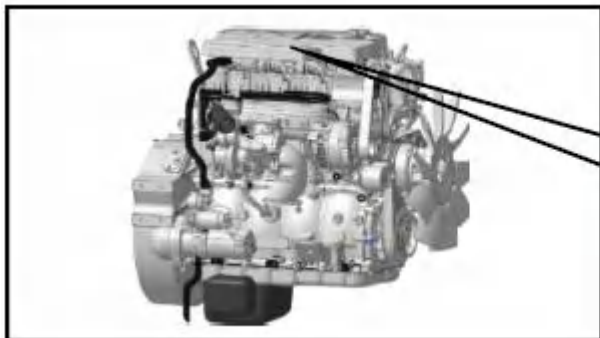

The engine number is marked on the engine cylinder. The upper part of the cylinder head of the engine is riveted with the engine sign. It is marked with engine model and factory number, calibrated power, calibrated speed, maximum net power, factory date, etc. Please pay attention to finding the specific location for easy use and maintenance.

## **Running-in of new vehicle**

In the initial running-in period, the new vehicle must be carried out strictly according to the running-in specifications, otherwise the performance and service life of the vehicle will be adversely affected. Therefore, the following matters should be strictly observed during the initial running-in period of 2500 km:

1. In the first 2500 km, the speed shall not exceed 80% of the maximum speed of the engine. When driving, please pay attention to the tachometer to avoid overspeed of the engine.
2. Overspeed, rapid acceleration, sudden start and unnecessary emergency brake of the engine shall be avoided.
3. The maximum load during running-in period is not more than 50% of rated load mass.
4. Before each start, the engine must run at idle speed until it reaches the normal working temperature.

## **Overload warning**

Overloading will not only shorten the service life of vehicles, but also may cause serious mechanical faults and even lead to accidents.

The load must be limited to the maximum total mass rating of the vehicle, and the load distribution of the front and rear axles should not exceed the bearing capacity of the axles, and the load mass should be evenly distributed in the container as far as possible.

## **Operation and management of vehicles**

All components and devices of the vehicle shall be checked in accordance with the requirements of the sections, including "Control device and instrument", "Before driving", and "Driving operations".

## **Maintenance and repair**

“”

In order to keep the vehicle in good technical condition and ensure driving safety, please check and adjust according to the requirements of "Maintenance and repair".

### **Precautions**

1. For all kinds of sensors, injectors, ECU and fuel filters on the engine of the electronic control system, if there is any fault, user shall not replace and repair them without permission. Please go to the Special Repair Station of our company for maintenance.
2. In order to prevent water from entering the electronic throttle, instrument pipeline, sensors, etc., it is forbidden to wash the ECU, relay box, sensors and harness butt joints in the cab and on the frame directly with water to prevent damage.
3. For the urea pump, urea nozzle, urea tank, various sensors and corresponding pipelines of

SCR after-treatment system, if there is any fault, the user shall not replace and repair them without permission, please go to the Special Repair Station of our company for maintenance.

4. In order to prevent SCR system fault, the urea used must be Weichai special urea, and the urea injection system should be maintained according to the maintenance requirements.

## Cab turnover mechanism

### Cab turnover

Single-row and one-and-a-half row cab can be turned upwards and forwards by 430 for easy maintenance.

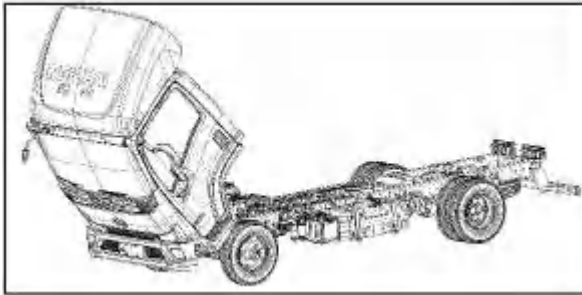

:

The specific operation is as follows:

1. When turning over, first pull the safety lock

hook A outward through the flip handle bracket D with the left hand to open the pull rod, and then pull the control handle C outward with the right hand

2. After the control handle C is opened, hold the flip handle bracket D firmly with your left hand, and pull the limit handle B outward with your right hand.

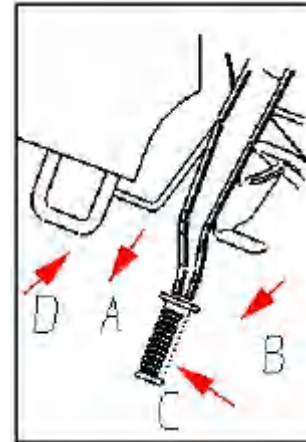

3. Hold the flip handle bracket with your right

hand and slowly flip the cab upward.

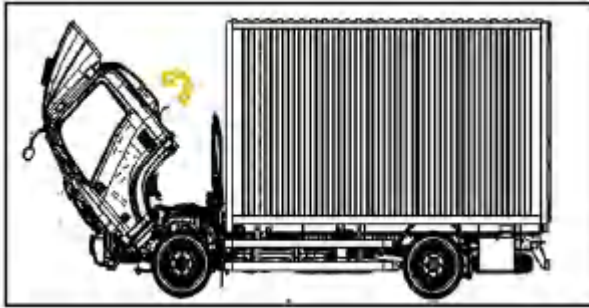

4. After the cab is turned over to a certain angle, the self-locking handle on the flipping support will automatically lock and support the cab under the tension of the spring. To ensure safety during the prolonged flipping of the cab, please insert the safety lock pin.

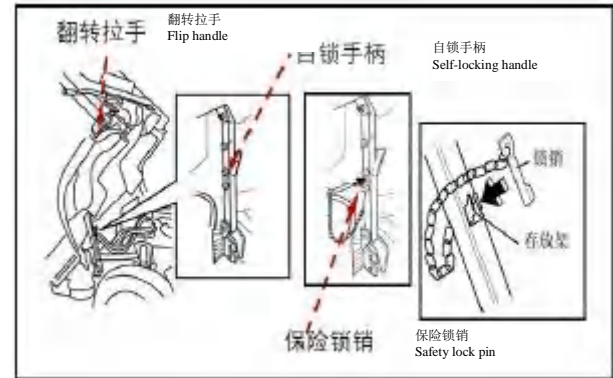

锁销  
Lock  
pin

存放架  
Storage  
rack

## Cab locking

1. Open the safety lock pin, hold the flip handle firmly with your left hand, and open the self-locking handle with your right hand. The cab will automatically flip under the action of self-weight.

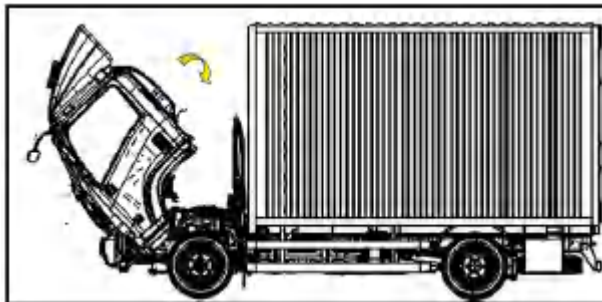

2. After the cab drops to a certain angle, the speed will slow down. Hold the flip handle bracket with your left hand and press it down until the lock hook hooks the lock hook limit bracket on the frame.

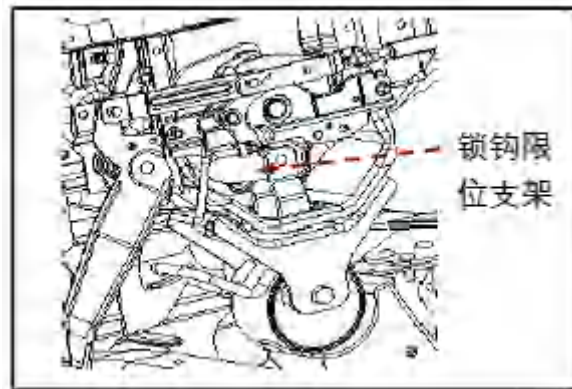

### Attention

**When the cab automatically turns down, avoid body parts such as the head and hands under the cab.**

3. Then hold the control handle with your right hand and press it down until the safety lock hook securely locks the control handle.

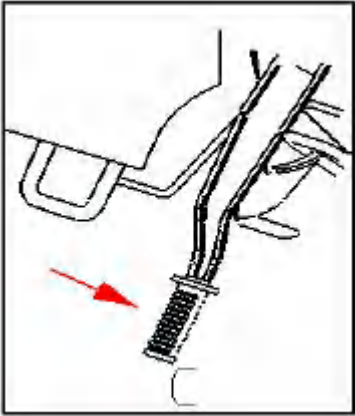

---

**time, insert the safety lock pin on the flipping support.**

---



**Warning**

---

**When locking the cab downward, do not pull down the locking handle;**

**When the cab is turned over for a long**

---

# Control device and instrument

## Instrument panel

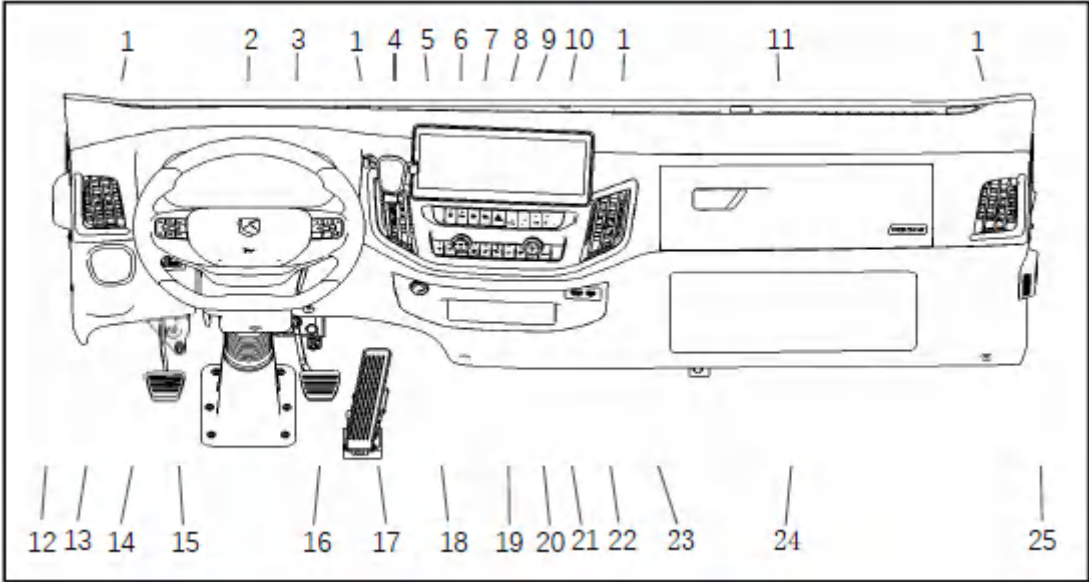

1 Instrument panel face blowing air inlet 2 Combination instrument 3 Horn button 4 Mobile phone support (some models) 5 Audio 6 Front fog lamp switch 7 Electric horn change-over switch 8 DPF manual parking regeneration switch 9 DPF regeneration disable switch 10 Air conditioning controller panel 11 Tool kit 12 Clutch oiler cover plate 13 Cup tray 14 Headlamp adjustment switch 15 Clutch pedal 16 Brake pedal 17 Accelerator pedal 18 24V power interface 19 Emergency alarm lamp switch 20 ESC off switch 21 Tachographs access cover 22 USB fast charge interface 23 Multimedia data transmission interface 24 Fuse box access cover 25 Windshield washer cover plate

## Instrument panel

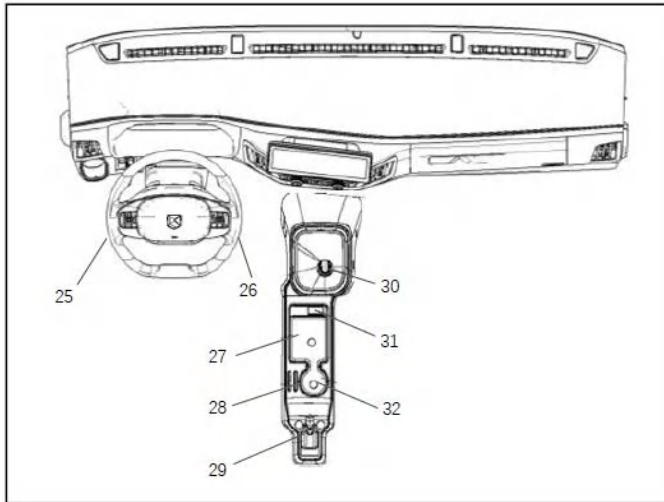

25 Combination switch left handle - light

26 Combination switch right handle - wiper

27 Storage box

28 Card slot

29 Brake hand valve

30 Shift lever

31 USB charging interface

32 Cup tray

## Instruments and indicator (some models)

### Instrument and indicator

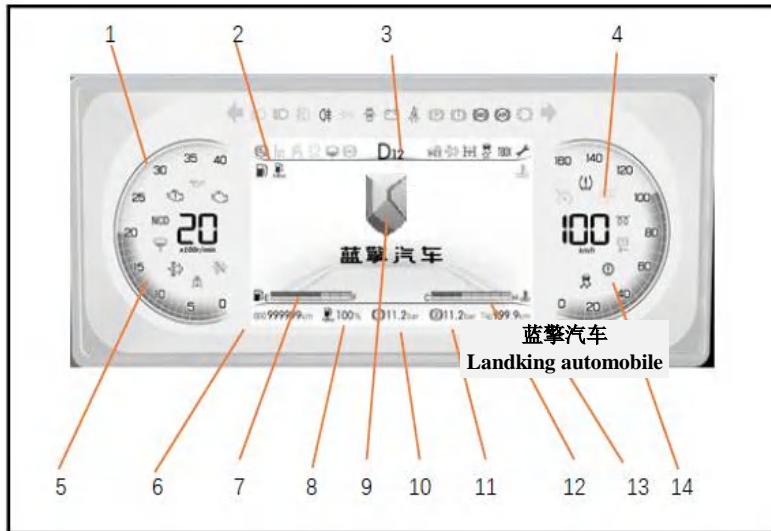

- 1 Tachometer
- 2 Indicator and diagnostic lamp
- 3 Gear
- 4 Speedometer
- 5 Indicator and diagnostic lamp
- 6 Total mileage
- 7 Fuel gauge
- 8 Urea liquid level percentage
- 9 LOGO
- 10 Front axle barometer
- 11 Rear axle barometer
- 12 Coolant temperature gauge
- 13 Subtotal mileage
- 14 Indicator and diagnostic lamp

## Instruments and indicator (some models)

### Instrument and indicator

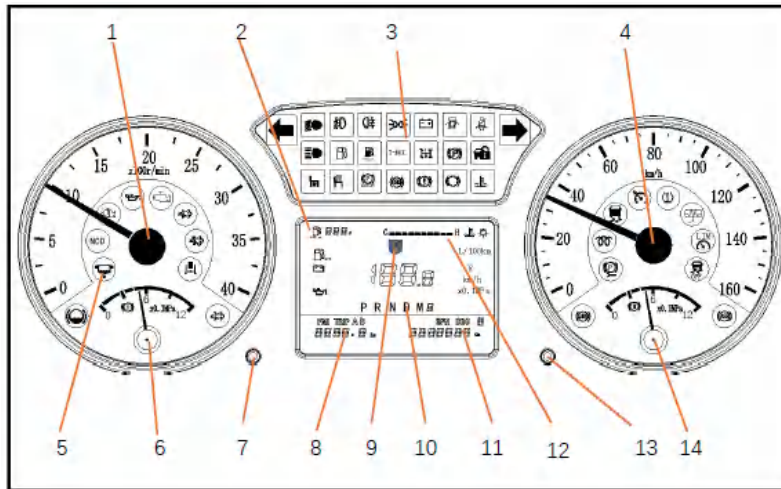

- 1 Tachometer
- 2 Urea meter and fuel gauge
- 3 Indicator and diagnostic lamp
- 4 Speedometer
- 5 Indicator and diagnostic lamp
- 6 Front axle barometer
- 7 Instrument operation button - left
- 8 Subtotal mileage
- 9 LOGO
- 10 Gear
- 11 Total mileage
- 12 Coolant temperature gauge
- 13 Instrument operation button - right
- 14 Rear axle barometer

## Speedometer

Indicates the speed in km/h.



## Odometer

Records the accumulated driving distance of the vehicle in km.

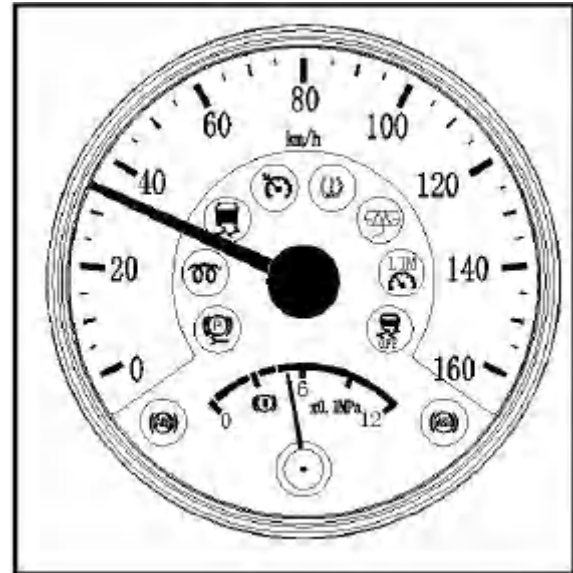

## Page turning and operation of display screen (some models)

The main interface of LCD screen includes LOGO, fuel gauge, water temperature gauge, indicator and fault light, urea liquid level and front and rear bridge air pressure.

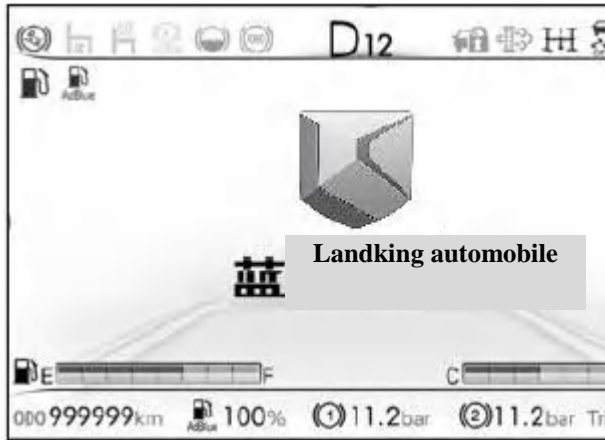

## Button adjustment (some models)

:

The instrument is adjusted by steering wheel button, which are divided into upturn, downturn and confirm buttons. The general design of buttons is as follows:

1. Short press the ( $\leq 1s$ ) upturn button: the number increases or the page switches in circle;
2. Short press ( $\leq 1s$ ) the downturn button: the number cycle decreases or the page switches in circle;
3. Short press ( $\leq 1s$ ) the confirm button: enter the page or exit the interface;
4. Long press the ( $> 2s$ ) confirm button: clear the subtotal mileage.

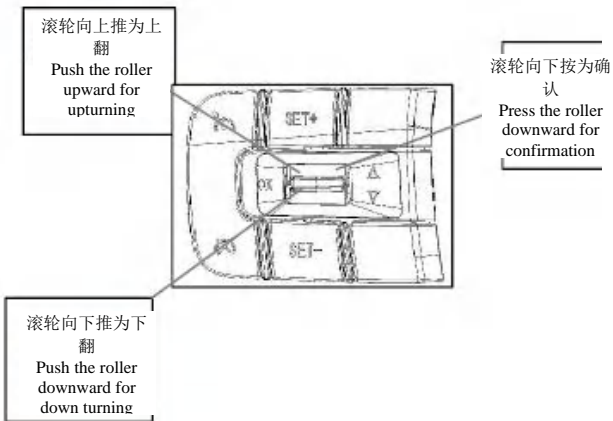

## Content and operation of main interface display screen (some models)

The main interface of the display screen includes LOGO, oil mass, urea liquid level, coolant temperature gauge, brightness adjustment, vehicle speed, average fuel consumption, vehicle voltage, engine oil pressure, subtotal mileage, total mileage and fault code.

## Button adjustment (some models)

### Button function description:

1. Short press ( $\leq 1s$ ) the left button: the number increases in circle or area cycle or page turning;
2. Long press ( $> 2s$ ) left button: save single data or enter;
3. Short press ( $\leq 1s$ ) right button: save the whole data or switch the main interface or switch the

internal entries of the area;

4. Long press (> 2s) right button: return to the main interface or clear subtotal mileage A.

## **Subtotal mileage reset**

In the main interface, long press the confirm button, and the subtotal mileage will be cleared.

## **Mileage information (some models)**

Short press the left button 4 times in the main interface, and the subtotal mileage A and total mileage will be displayed by default:

a. If you don't operate for 5s, exit the setting and return to the main interface (showing subtotal mileage A and total mileage).

b. Short press right button, switch to display subtotal mileage B and total mileage. If you don't operate for 5s, exit the setting and return to the main interface (display subtotal mileage B and total mileage).

c. Long press the right button to clear the subtotal mileage.

## **Diagnostic lamp**

When the whole vehicle has relevant faults, the corresponding diagnostic lamps will light up.

## **ECU (some models)**

The ECU interface is divided into fuel consumption, oil pressure, voltage and tire pressure monitoring (some models) interfaces.

Short press the upturning or downturn button in the main interface to enter the ECU interface.

The fuel consumption interface shows the

average fuel consumption of the vehicle per 100 kilometers.

The oil pressure and voltage interface displays the relative oil pressure of the engine and the vehicle voltage.

The tire pressure monitoring interface is only available when the vehicle is equipped with tire pressure monitoring, which displays the tire pressure and tire temperature information of each tire.

### **ECU (some models)**

ECU interface is divided into fuel consumption, voltage and oil pressure interface.

Short press the left button 3 times in the main interface to enter the ECU interface.

The fuel consumption interface shows the average fuel consumption of the vehicle per 100 kilometers.

The oil pressure and voltage interface displays the relative oil pressure of the engine and the vehicle voltage.

### **Fault information (some models)**

Short press the left button 4 times in the main interface, and then short press the right button 2 times to switch and display the fault information FMI and SPN code. Long press the left button to enter SPN and FMI page turning mode, Short press the left button to turn pages, and long press the right button to return to the main interface and save the settings.

Short press right button again to switch to fault code device selection, and short press left button, the number will cycle between 1, 2, 3 and 4

(number corresponding definition: EDC-1; ABS-2; AMT-3; EPB-4). When there are multiple fault codes in one controller, SPN and FMI will be displayed in circle



## Menu function

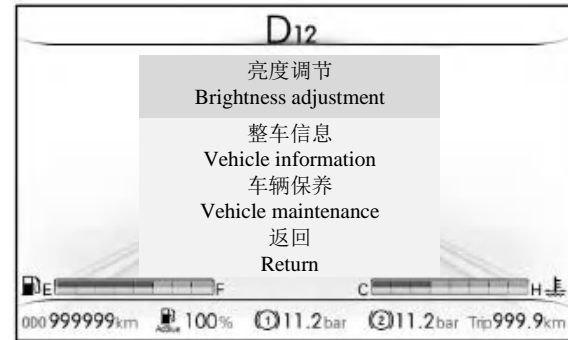

Menu functions are divided into three items, namely brightness adjustment, vehicle information and vehicle maintenance. Short press the confirm button in the main interface to display brightness adjustment, vehicle information and vehicle maintenance menu. Short press the downturn button to switch between brightness adjustment, vehicle information and vehicle maintenance. Short press the upturning button to switch between vehicle maintenance, vehicle information and brightness adjustment respectively (in other interfaces, release the buttons for 1 minute and automatically return to the main interface). When

downturn to "Return", short press the confirm button to return to the main interface.

## Brightness adjustment (some models)

When the brightness adjustment is selected in the menu interface, short press the confirm button to enter the brightness adjustment interface.

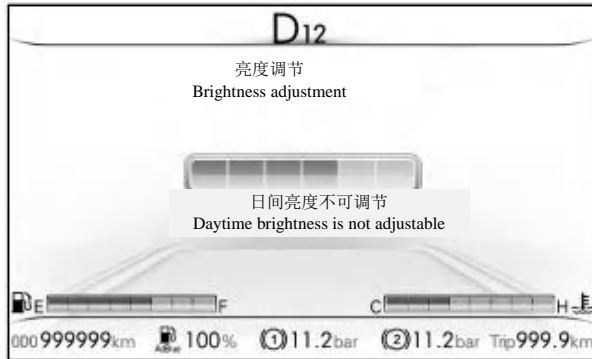

The brightness adjustment can only be adjusted when the sidelight is turned on.

The brightness adjustment is divided into six levels. Short press the upturning button, and the brightness increases. Short press the downturn button, and the brightness decreases. After adjusting to the appropriate brightness, short press the confirm button, save the brightness and return to the previous level.

After disconnecting ON power or battery power, brightness adjustment can be saved.

## Brightness adjustment (some models)

Short press the left button twice in the main interface, then short press the right button, and then long press the left button to enter the brightness adjustment mode. Short press the left button to adjust the brightness, and the brightness changes in circle.

The brightness adjustment is divided into 8 levels. Short press the left button, and the brightness changes in circle. After adjusting to

the appropriate brightness, long press the right button, save the brightness and return to the main interface.

After disconnecting ON power or battery power, brightness adjustment can be saved.

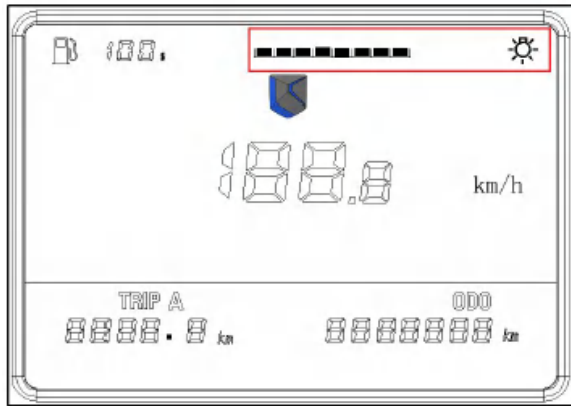

## Vehicle information

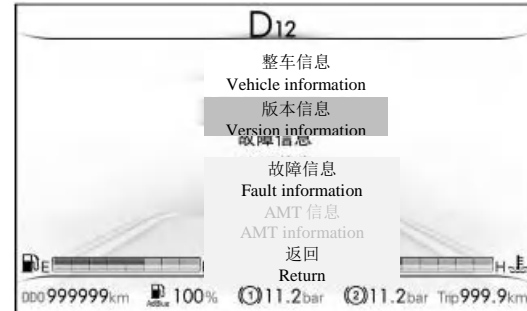

When the vehicle information is selected in the menu interface, short press the confirm button to enter the vehicle information interface.

Vehicle information includes version information, fault information and AMT information. Short press the downturn button on the vehicle information page to switch between version information, fault information and AMT information in turn; short press the upturning button to switch between AMT information, fault information and version information in turn.

When down turning to "Return", short press the confirm button to return to the previous level.

## Oil mass and urea level display (some models)

It displays the fuel mass in the fuel tank.

Indicates the amount of urea stored in the urea tank.

Short press the left button once in the main interface to display the oil mass information by default, and then short press the right button to switch to display the urea level. Release the button for 5s or long press the right button to exit the setting and return to the driving interface (display urea level).

## Version information



When the version information in the vehicle information is selected, short press the confirm button to enter the version information interface and display the software and hardware versions of the instrument.

In the version information interface, short press the confirm button to return to the previous level.



## Fault information

Selecting the fault information in the vehicle information will enter the fault information interface.

Fault information includes EDC fault, ABS

fault, AMT fault and EPB fault.

Short press the downturn button in the fault information interface to switch between EDC fault, ABS fault, AMT fault and EPB fault, and short press the upturning button to switch between EPB fault, AMT fault, ABS fault and EDC fault. When down turning to "Return", short press the confirm button to return to the previous level.

When the EDC fault is selected, short press the confirm button to enter the EDC fault interface and display the SPN and FMI of the fault. Short press the confirm button to return to the previous level.

## AMT

### AMT information

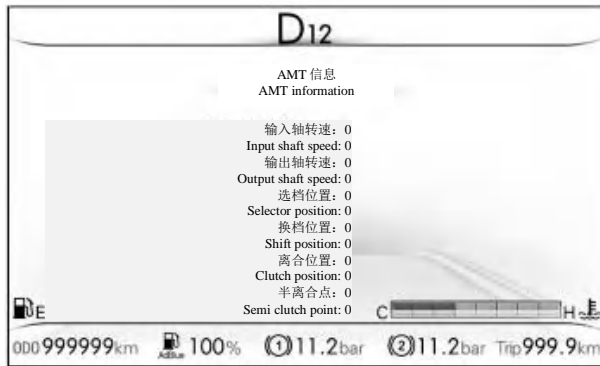

When the AMT information in the vehicle information is selected, short press the confirm button to enter the AMT information interface.

The AMT information page contains the gearbox self-learning status and the gradient sensor self-learning status.

Short press confirm button to return to the previ

### Vehicle maintenance



When vehicle maintenance is selected in vehicle information, short press the confirm button to enter the vehicle maintenance interface.

The vehicle maintenance page displays the remaining maintenance mileage of each maintenance item of the vehicle.

In the maintenance mileage interface, short press the downturn button to switch between engine maintenance mileage, gearbox maintenance mileage, rear axle maintenance mileage and rear axle hub maintenance mileage, and short press the upturning button to switch between rear axle hub maintenance mileage, rear axle maintenance mileage, gearbox maintenance mileage and engine maintenance mileage.

When down turning to "Return", short press the confirm button to return to the previous level.

## Vehicle speed information

Display in digital form.

## Gear information (AMT)

It displays the current gear of AMT gearbox, N, R, D and M.

The MT gearbox does not display gear information.

## Barometer

It displays the air pressure of front axle and rear axle.

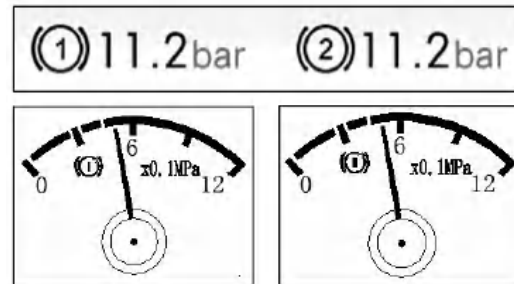

## Water thermometer



When the ignition switch is turned to the "ON" position, the coolant temperature gauge will indicate the temperature of the coolant. The coolant temperature gauge is displayed as a columnar bar, and the coolant temperature begins to display when it reaches 40 °C. With the increase of coolant temperature, it gradually increases, and when the temperature reaches the alarm area, it is displayed as red and buzzers alarm.

If the coolant temperature gauge reaches the alarm red area, it indicates that the engine is overheated. Please ask the driver to handle it according to the relevant rules in the chapter "Driving operation" of this Manual in time. Otherwise, the engine will continue to work in an

overheated state, which will lead to serious damage to the engine.

## Tachometer

It indicates the engine speed per minute (r/min).

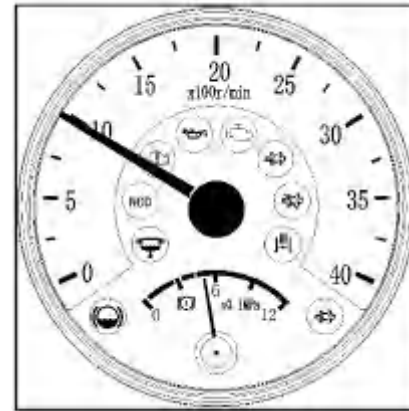

## Fuel gauge

The fuel gauge shows the fuel quantity in the fuel tank.



Instrument and indicator

## Urea level display

Indicates the amount of urea stored in the urea tank.

## Turn signal indicator and emergency alarm lamp

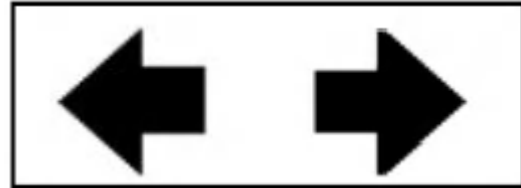

When the switch of turn signal indicator or

emergency warning is turned on, the turn signal indicator begins to flash, indicating that the external turn signal indicates the direction or the emergency warning lamp (left-right turn signals flash at the same time) is working normally.

When the switch of left turn signal indicator is turned on, the left turn signal indicator begins to flash.

When the switch of right turn signal indicator is turned on, the right turn signal indicator begins to flash.



**Warning**



**When your vehicle becomes a traffic hazard, please use the emergency alarm lamp to attract the attention**

---

**of other drivers.**

---

### **High beam lamp indicator**

When the headlamp is converted to the high beam indicator, the latter will be lit, which indicates that the high beam of headlamp is working normally.



## Rear fog lamp indicator



When the following conditions are met, the rear fog lamp and the rear fog lamp indicator are lit: when the ignition switch is ON, the sidelight switch is turned on, and the headlamp switch or the front fog lamp switch is turned on, if the rear fog lamp switch is turned on, the rear fog lamp indicator and the rear fog lamp is turned on.



## Warning

---



When driving in foggy weather or low visibility environment, please turn on the fog lamp switch and turn on the fog lamp to ensure driving safety.

---

## Low oil pressure alarm lamp

When the ignition switch turns to the "ON", the low oil pressure alarm lamp is lit; When the engine is started, the alarm lamps go out. If the warning lamp of low oil pressure is lit when the vehicle is running, indicating that with ultra-low oil pressure, the vehicle should be parked immediately and checked the oil level in the engine crankcase. If the height of oil level is normal, you should check and repair the vehicle at our special maintenance station.

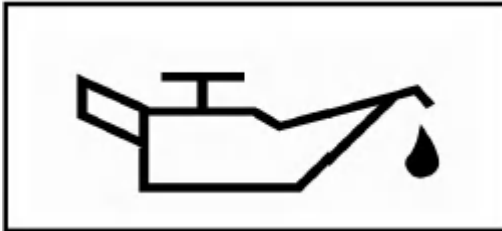

## Warning

---

- **Do not run the engine when the low oil pressure warning lamp is on.**

---

## Brake fault alarm lamp



If the brake fault alarm lamp is lit during vehicle driving, it means that with ultra-low air pressure, the vehicle should be parked at once for inspection and troubleshooting. If the fault cannot be eliminated, go to the professional service station for inspection and maintenance on the basis of ensuring safety.

When the ignition switch is turned to the "ON" position, the brake fault alarm lamp lights up for 3s at the self-check point and then lights up if the air pressure value is lower than the alarm point and the buzzer beeps intermittently.

If the air pressure value exceeds the alarm point, the diagnostic lamp will go out and the buzzer will stop buzzing.

**immediately.**

## **Oil-water separation alarm lamp**

When the water level in the oil-water separator is higher than the alarm value, the alarm lamp is lit.



### **Attention**

- **When the vehicle is running, if the warning light is on, stop and drain**

## **Parking brake indicator**



When the ignition switch is in the "ON" position and the parking brake handle is pulled up or the EPB switch is turned on, the parking brake indicators up.

When parking works, the parking brake indicator lights up. If the vehicle speed is greater than or equal to 5 km/h at this time, the buzzer starts to beep intermittently.

### **Low fuel level alarm lamp**

When the fuel gauge indicates to the red alarm area (1/8), the low fuel level alarm lamp lights up. At this time, the fuel should be replenished in time.



### **Preheating indicator**

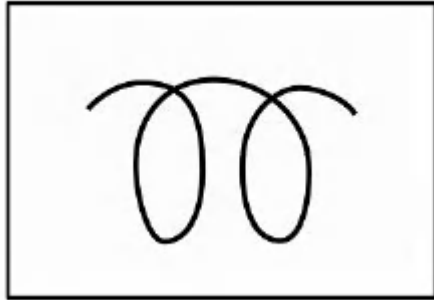

generator is started, the lamp goes out when the charging circuit of generator is normal.

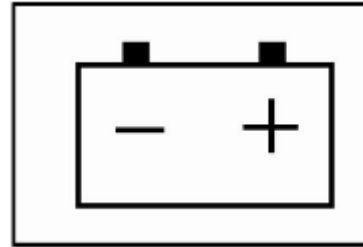

After the ignition switch is turned on, ECU judges whether heating is needed and the heating time. When ECU starts preheating, the preheating indicator lights up, and when the time reaches, the indicator goes out. Prompt the driver to start the engine.



### Attention

### Charging fault alarm lamp

When the ignition switch is "ON", the alarm lamp of generator charging fault is lit; After the

**When the vehicle is running, if the alarm light is on, check the generator circuit at the nearest professional maintenance point. If the generator belt is broken or loose, please do not continue driving.**

## Exhaust brake indicator

When the exhaust brake switch of the vehicle is turned on, the indicator lights up. When the exhaust brake switch is disconnected, the indicator goes out.

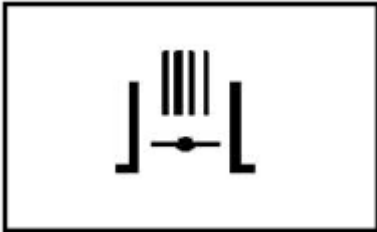

## Sidelight indicator

When the ignition switch is turned to the "ON" position and the combination switch is rotated to the sidelight indicator gear, the

indicator will light up and the instrument backlight will light up at the same time.



**ESC**

**ESC indicator (some models)**

When the body stability control system is faulty, the indicator is always on. When the ESC is working, the indicator flashes.



When ESC OFF is pressed, the indicator displays ESC OFF.

**ESC OFF Indicator (some models)**



## OBD diagnostic lamp

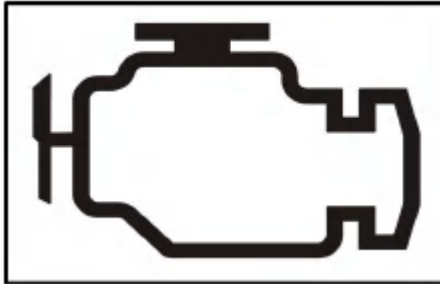

When the ignition switch is turned to the "ON" position, the indicator flashes at intervals and goes out after starting. If the emission related system is abnormal, this lamp is lit, which indicates that the emission system is faulty and required to be repaired in the maintenance station in time.

## Engine fault alarm lamp

When the ignition switch is ON, the engine should be self-checked, turning ON first and then turning off. When the ECU of engine detects that there is a serious fault in the system, the lamp is lit. This fault lamp can remind the operator of the serious fault, thus stopping for maintenance immediately.

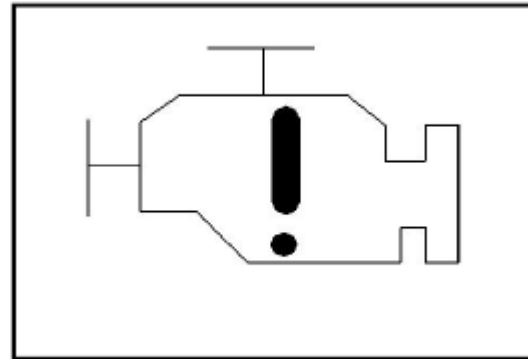

## Safety belt alarm lamp

Safety belt alarm lamps are used to remind drivers to fasten their safety belts. There are two alarm states:

The alarm lamp is always on (no beeps). The indicator flashes + beeps.

If the seat belt is not fastened, with a speed of less than 25 km/h, the light remains on. When the speed is greater than or equal to 25 km/h, the alarm lamp flashes for 90s and beeps for 90s. After the alarm lamp flashes, regardless of the speed change, the flashing time is fixed at 90s.

Without wearing a safety belt, the lights will be on normally after flashing for 90 seconds. Even if the vehicle speed is greater than or equal to 25 km/h again, it will no longer flash.

After the safety belt is inserted, the lamp goes out, and the buzzer stops buzzing.



### **Urea level alarm lamp**

With low urea level, the urea level alarm lamp is lit.



### **Door opening alarm lamp**

The door opening alarm lamp is lit as it is not closed.



### **High coolant temperature alarm lamp**

When the coolant temperature is higher than the alarm point, the alarm lamp lights up and goes out when it drops to the alarm point.

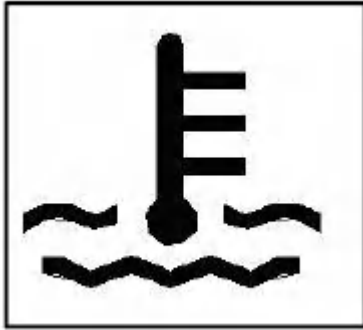

### **PTO Indicator (some models)**

It lights up when the power take-off working.

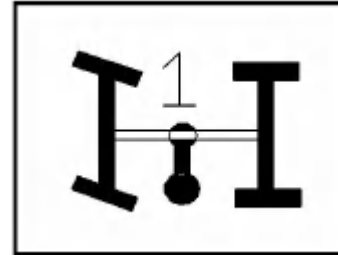

### **ABS**

#### **ABS diagnostic lamp**

1. Turn the ignition switch to ON gear, the system self-checks, and the ABS diagnostic lamp lights up first and then goes out.
2. When the ABS system is faulty, the ABS diagnostic lamp is always on.

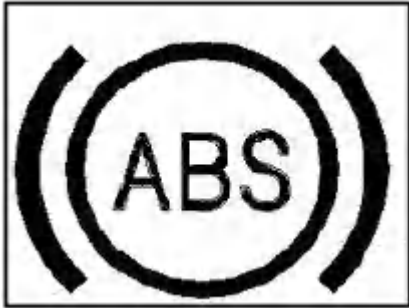

### **Seat ventilation indicator (some models)**

When the ignition switch turns to the "ON" position, the seat ventilation function works and the seat ventilation indicator lights up.

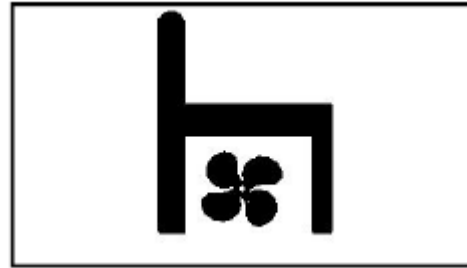

### **Seat heating indicator (some models)**

When the ignition switch is turned to the "ON" position, turn ON the seat heating switch, the seat heating works, and the seat heating indicator lights up.

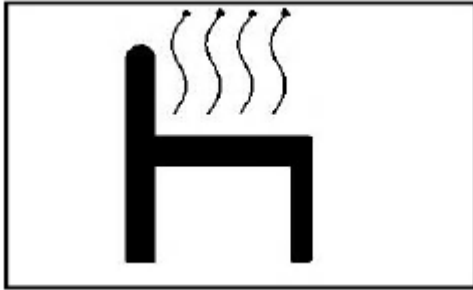

**Rearview mirror heating indicator**

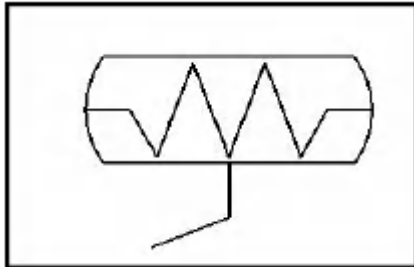

When the ignition switch is turned to the

"ON" position, the rearview mirror heating switch is turned on and the rearview mirror heating indicator lights up.

**EPB diagnostic lamp (some models)**



When the EPB system fails, the EPB diagnostic lamp lights up.

**EBD diagnostic lamp (some models)**

When the EBD system fails, the EBD diagnostic lamp lights up.

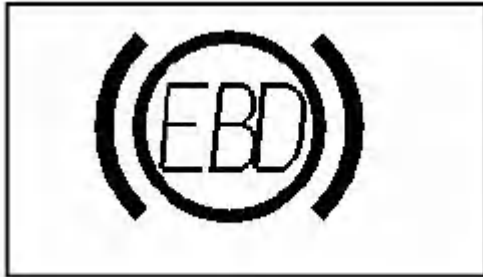

### **Gearbox diagnostic lamp (some models)**

When the gearbox fails, this lamp lights up and needs to be stopped for maintenance immediately.



### **DPF**

### **DPF regeneration indicator**

When the DPF lamp flashes yellow, the driver should find a safe place as soon as possible and stop for in-situ regeneration (by pressing DPF manual parking regeneration switch).

When the DPF lamp is always red, it is important to prompt the driver to go to the service station for DPF service regeneration.

When the DPF lamp remains at yellow, the engine speed will be higher than the normal speed in case of special circumstances such as red light, which is normal.

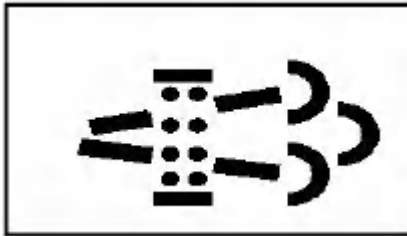

### **DPF regeneration prohibition indicator**

When the regeneration prohibition switch is pressed, the regeneration prohibition indicator is lit. Since there is a driving regeneration process for DPF, in some cases, when the vehicle is driving in an unsafe area, it is necessary to press the switch to temporarily stop any regeneration

process to avoid safety accidents from the high temperature gas.

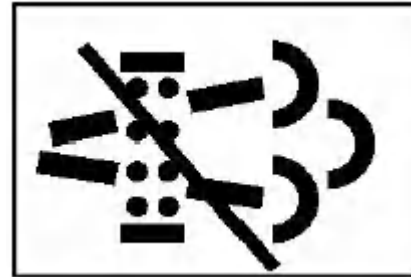

### **Cruise control indicator**

After the cruise function is on, the green cruise working indicator is lit.

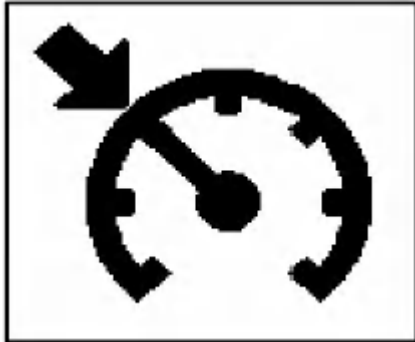

### **Low beam lamp indicator**

When the switch of low beam indicator is turned on, it will be lit.

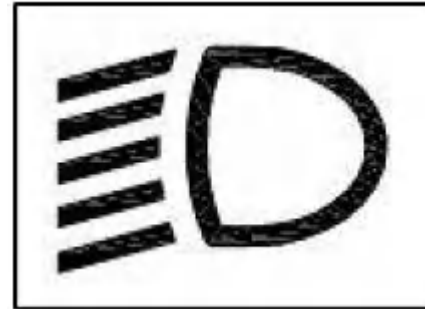

### **Front fog lamp indicator (some models)**

When the ignition switch is ON, the sidelight switch is pressed, or the headlamp switch is turned on, if the front fog lamp switch is pressed, the front fog lamp indicator and the front fog lamp light up.



### **Driver warning lamp**

When the ignition switch is turned to the "ON" position, the driver alarm lamp goes out after self-check. When the system detects a fault, the driver's alarm lamp lights up or flashes, and the vehicle shall be repaired immediately at the Special Repair Station of our company.



### **Tire pressure monitoring alarm lamp (some models)**

When the ignition switch is turned to "ON" gear, the alarm lamp self-checks, and if there is no problem with tire pressure, the alarm lamp goes out. When the system detects a fault, the tire pressure monitoring alarm lamp lights up and the buzzer sounds (the tire pressure interface displays specific tire pressure information), and you should immediately go to the Special Repair Station of our company for maintenance.



### **Maintenance reminder**

When the vehicle arrives or approaches the maintenance time, the indicator lights up and beeps several times to remind the user to go to the 4S shop for maintenance.

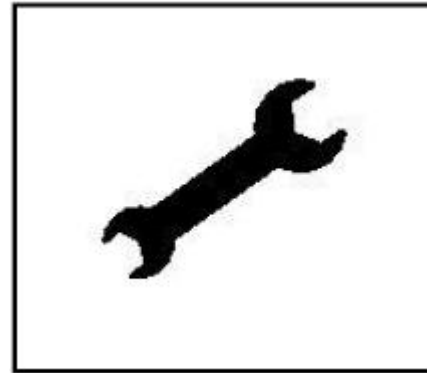

### **Attention**



**After tire transposition, the tire position should be calibrated again at the Special Repair Station of our company to ensure that the position of the tire pressure monitoring module corresponds to the**

information displayed by the instrument one by one.



The spare tire is not equipped with a tire pressure monitoring module, and the tire pressure monitoring system cannot display its tire pressure information.



When the tire is not replaced due to the damaged tire pressure monitoring module, as the tire pressure monitoring module transmits information by radio frequency, the tire pressure monitoring system will always monitor the tire pressure information as long as the tire is still on the vehicle. At this time, the tire pressure information of the spare

**tire in use cannot be monitored.**

**AUTO HOLD (some models)**

When the AUTO HOLD function is active, the indicator is always on.



## HHC (some models)

Press the HHC button and the indicator will light up.



## Shoe wear alarm lamp

When the ignition switch is turned to "ON" gear, when the brake shoes are abnormally worn, the alarm lamp lights up, indicating that the brake shoes shall be replaced.



**TBOX**

**TBOX alarm lamp**

When the TBOX is damaged or removed, the TBOX alarm lamp lights up.



**ASR**

**ASR system operating indicator (some models)**

Flash: ASR system is working.

Constant lighting: ASR function is turned off.



**Cold compartment front temperature alarm lamp (refrigerated truck)**

If the temperature of the front part of the cold compartment exceeds the temperature range set by the instrument, the front temperature alarm lamp (yellow light) will be activated.

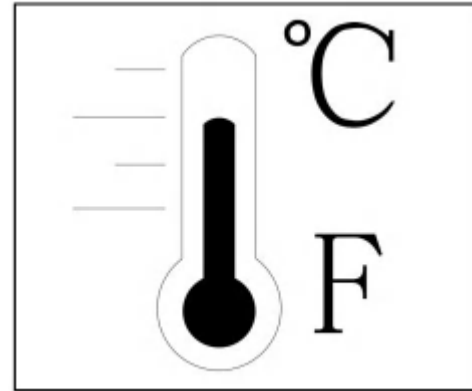

**Cold compartment rear temperature alarm lamp (refrigerated truck)**

If the temperature at the rear of the cold compartment exceeds the temperature range set by the instrument, the rear temperature alarm lamp (yellow lamp) will be activated.

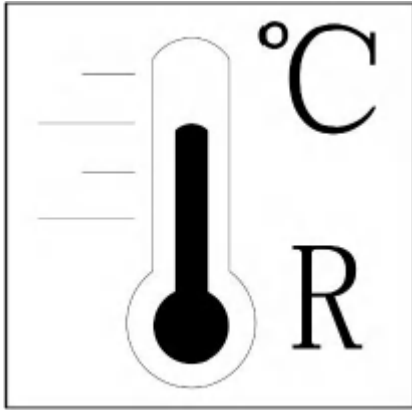

remind drivers and passengers that the middle door of the compartment is unlocked.

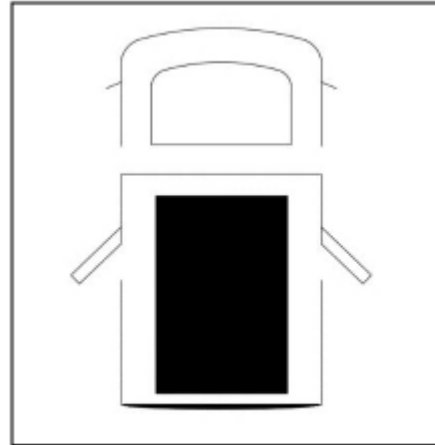

### **Compartment middle door opening alarm lamp (refrigerated truck)**

When the vehicle is powered on, if the middle door of the cold compartment is opened, the opening alarm lamp (yellow light) of the middle door in the instrument will be activated to

### **Compartment rear door opening alarm lamp (refrigerated truck)**

When the vehicle is powered on, if the rear door of the cold compartment is opened, the

opening alarm lamp (yellow light) of the rear door in the instrument will be activated to remind drivers and passengers that the rear door of the compartment is unlocked.

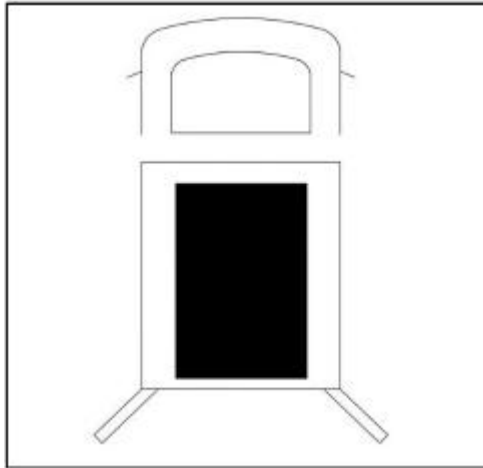

**Primary warning of FCW vehicles (some models)**

If the system detects that there is a vehicle ahead, and it calculates the estimated collision time according to the signal fed back by radar. When it is too close to the vehicle ahead, the instrument lights up the primary warning indicator (yellow light) of the vehicle, and the instrument gives an alarm sound.



**FCW  
FCW vehicle collision warning (some models)**

If the system detects that there is a vehicle ahead, and it calculates the estimated collision time according to the signal fed back by radar. When the collision is about to occur, the instrument lights up the vehicle collision warning indicator (red light), and the instrument gives an alarm sound. Vehicles equipped with AEBS function will automatically brake urgently.



**Attention**

---

**When the automatic emergency braking function is started more than 10 times, the function will be disabled. It is necessary to contact the special service station for restoration.**

## FCW

### FCW pedestrian primary warning (some models)

If the system detects that there is a pedestrian ahead, and it calculates the estimated collision time according to the signal fed back by radar. When it is too close to the pedestrian ahead, the instrument lights up the pedestrian primary warning indicator (yellow light), and the instrument gives an alarm sound.



### FCW pedestrian collision warning (some models)

The system detects the presence of pedestrians in front, and calculates the estimated collision time according to the signal fed back by radar. When the collision is about to occur, the instrument lights up the pedestrian collision warning indicator (red light) and gives an alarm sound. Vehicles equipped with AEBS function will automatically brake urgently.



### **Left lane deviation warning (some models)**

During high-speed driving, as LDWS detects that the driver does not turn on the turn signal lamp, and the vehicle deviates to the left lane, the instrument lights up the left lane departure warning indicator, and the instrument gives an alarm sound.



### **Right lane deviation warning (some models)**

During high-speed driving, LDWS detects that the driver does not turn on the turn signal lamp, and the vehicle deviates to the right lane. The instrument lights up the right lane departure warning indicator, and the instrument gives an alarm sound.

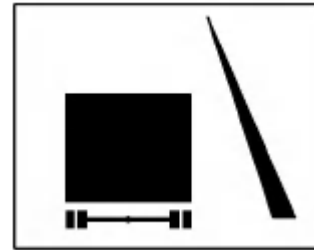

### **LDWS fault indicator**

When LDWS fails, the instrument lights up the LDWS fault indicator (yellow light).



### **LDWS function on**

After the vehicle starts, LDWS function is turned on by default without indicator lighting.

### **LDWS function off**

When the LDWS function is turned off (the LDWSOFF button is pressed), the instrument lights up, and the reminder function is turned off (green). Instruments of some models are not displayed.



### **AEBS fault**

In case of AEBS faults, the instrument will light up the AEBS fault indicator (yellow light).



### **AEBS function on**

After the vehicle starts, AEBS function is

turned on by default without indicator lighting.

### **AEBS function off**

When the AEBS function is turned off (the AEB<sub>SOFF</sub> button is pressed), the instrument lights up, and the reminder function is turned off (green).



### **FCW fault (some models)**

When the collision warning system fails, the instrument lights up the FCW fault indicator

(yellow light).



### **FCW function enabled (some models)**

After the vehicle starts, FCW is turned on by default (green). If FCW double warning switch is pressed, FCW system function will be turned off.



### **Manually turning off the switch of the advanced assisted driving system**

The AEBS function and LDWS function can be temporarily turned off by manually turning off the switch of the advanced assisted driving system. When the vehicle restarts, AEBS and LDWS functions are turned on by default.



### **Precautions**

The core components of the advanced assisted driving system are all composed of precision electronic components. On the premise of correct use, it is necessary to carry out daily maintenance and inspection on the millimeter wave radar, front-view camera, ESC system, and harness.

Always check whether there are obstructions or other things in front of and on the surface of the millimeter wave radar and vision sensor, otherwise, the AEBS/LDWS function will fail. The millimeter wave radar is blocked by dirt,

such as mud and surface icing, will also lead to radar failure.

The installation position of the millimeter wave radar cannot be changed. If the installation position of radars is misplaced due to external force factors such as violent vibration of the vehicle body and collision of the front bumper, signal misalignment will also occur, resulting in failure of the AEBS system. The installation position of radars needs to be checked or recalibrated.

It is strictly forbidden to disassemble and assemble the millimeter wave radar and change its installation position without authorization, and it is strictly forbidden to disassemble, assemble, modify, and paint the millimeter wave radar shield without authorization.

It is strictly forbidden to disassemble and

assemble the front-view camera and change its installation position without authorization.

In case of fogging of the front-view camera lens, defogging treatment is required.

Please note that millimeter wave radars or front-view cameras cannot detect dangerous obstacles ahead in all cases. The premise for AEBS to respond to relevant targets is that the targets must be in the field of view of sensors and recognized. The performance of AEBS will be greatly limited for cutting-in targets, targets detected only after the vehicle changes lanes, and targets in sharp turning roads.

Bad weather and road environments, such as heavy rain, heavy snow, heavy fog, haze, strong typhoons, dusty weather, and ice and snow roads, will lead to the decline of

system functions, so the driver had better shut down the system.

If the AEBS yellow light is on during the driving of the vehicle, it means that the AEBS system fails, but the vehicle can still be driven safely, that is, the conventional braking of the vehicle still works, but the early warning and automatic emergency braking of AEBS cannot work normally in case of emergency. In this case, the after-sales service department should be consulted or solve the problem.

In any case, the driver should be responsible for driving safely and avoiding dangerous situations.

## Control device

### Steering column control device

### Steering wheel and horn button



According to the different models purchased, the configuration of steering wheel is different, and the specific object shall prevail.

Press the horn button on the steering wheel and the horn will sound.

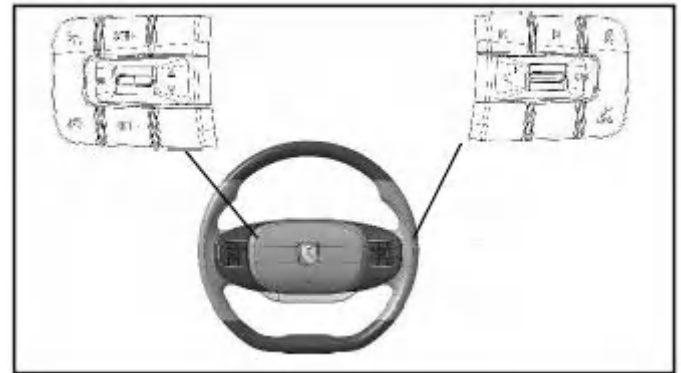

### Adjustable steering wheel

The steering wheel is within the adjustable range, and can be adjusted to any position up and down, back and forth according to the driver's own habits. Please adjust the steering wheel to the most comfortable position for the driver.

#### Adjustment step

1. Turn the steering wheel adjustment lock handle upward to release the steering column lock.
2. After sitting upright in the seat, move the steering wheel forward, backward, up and down to place it in the desired position.
3. Tighten the locking handle downward to lock the steering wheel in the required position.

## **Cruise control function**

### **Conditions for entering the cruise**

When driving normally, the driver is in gear 5 or above, the speed is greater than or equal to 30km/h, and the engine speed is within 600r/min–2800r/min. Press the cruise start key, and press the "+" key or "-" key again to enter the cruise state.

### **Adjustment of cruising speed**

After entering the cruise, you can use the cruise "+" key and the "-" key to increase or decrease the cruise speed. Every time you click the cruise "+", the speed will increase by 2km/h (default), and every time you click the "-", the speed will decrease by 2km/h (default); long press cruise "+" to increase the vehicle speed by 1.5 km/h/s (default), and long press cruise "-" to

reduce the vehicle speed by 1.5 km/h/s (default).



### Attention

●  
**Cruising is not recommended when encountering long and large slopes or poor road conditions.**

### Exit of cruise

You can exit the cruise by pressing the clutch, brake and exhaust brake. After the cruise exits in this way, you can directly press the Resume button to resume the cruise state, provided that the cruise activation conditions are still met when pressing the Resume button.

You can also exit the cruise by using the cruise

"OFF" button (OFF), but after exiting the cruise in this way, you can no longer enter the cruise by pressing the Resume button, so you need to press the "+" or "-" button again to activate the cruise.

You can temporarily quit cruising by using the accelerator pedal. For example, if the driver needs to overtake in the cruising state, the driver can increase the throttle opening. After releasing the accelerator pedal, the cruising state will not exit, and the original cruising state will continue to be maintained.

### Audio control function

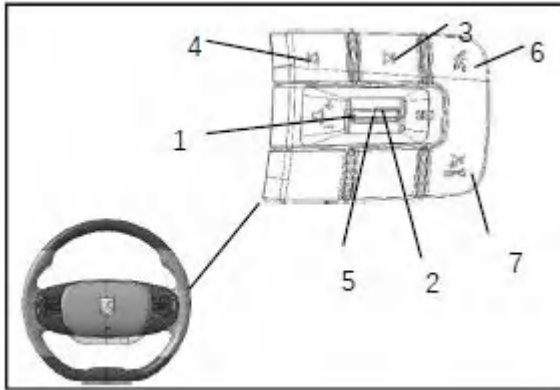

1. Turn the roller upward to increase the sound of multimedia.
2. Turn the roller downward to reduce the sound of multimedia.
3. After pressing, it is the next effective radio station in radio mode and the next track in USB

mode.

4. After pressing, it is the previous effective radio station in radio mode and the previous track in USB mode.
5. After pressing the roller, switch modes between radio or USB.
6. When a phone is connected, press this button to answer the call.
7. Press this button to hang up the phone; if there is no call, press this button, the audio is in mute state, and press it again to cancel mute.



### Attention



**Pay more attention when operating the switch on the steering wheel to avoid accidents.**

Ignition switch

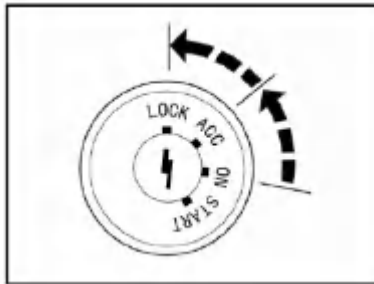

As shown in the figure, this switch has four transition positions:

"LOCK": the key can only be inserted or removed when the switch is in this position, and

the steering wheel is locked when the key is removed.

"ACC": when the key is placed in this position, even if the engine is not running, the accessory circuit can be energized for use.

"ON": this position is used for the power supply of the vehicle electrical equipment.

"START": turn the key to this position and the engine will start. As long as you release, the key will automatically return to the "ON" position.



### Attention

● **After the vehicle stalls, pull off the ignition switch, and the left and**

**right door will be unlocked automatically! (Some models)**



### **Danger**

**Never turn the key to the "LOCK" position while driving, otherwise it will cause great danger because the steering wheel is locked.**



### **Warning**



**After the engine starts, let go in time**

**to make the key reset automatically. The starter shall not work continuously for more than 10s.**

### Combination switch

The combination switch handle is composed of a light control switch, a rear fog lamp switch, a turn signal lamp switch, a headlamp dimmer switch, a passing light switch, a wiper switch, a windshield washing switch, and an exhaust brake switch.

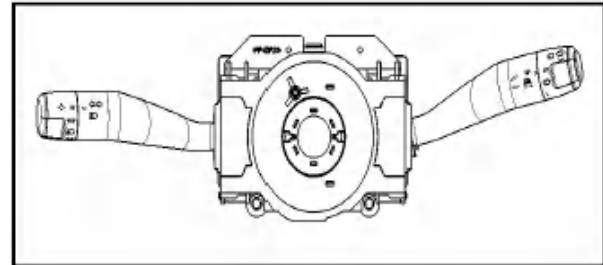

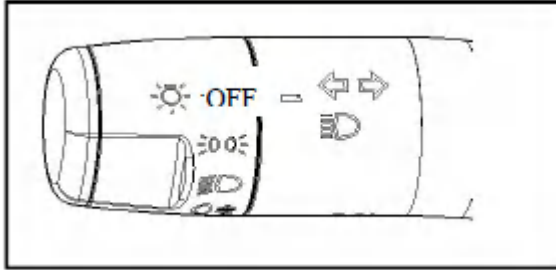

## Light control switch



The light control switch has four gears and turned on counterclockwise to control the following lights:

OFF gear: when placed in "OFF" gear, the following lights do not participate in the operation

 Gear: sidelight, rear light, license plate lamp and instrument panel backlight.

 Gear: all the above lamps and headlamp.

 Gear: all the above lamps and rear fog lamp.

1. When the ignition switch is turned to "ON", and the low beam, high beam, sidelight and front fog lamp switches are turned to "OFF", the left (right) steering switch is turned off, and the left (right) daytime running lamps are automatically lit when the non-parking braking is turned on.

2. When the low beam, high beam, sidelight or front fog lamp is turned on and the left (right) steering switch is turned on, the left (right) daytime running lamp is turned off. When the ignition switch is in non-"ON" gear or parking brake, the daytime running lamps are turned off.

## Turn signal switch

When the switch handle is flipped in the

desired direction, the external turn signal lamp lights up and the turn signal lamp indicator on the instrument panel flashes. When the steering wheel is turned back to the straight position, the switch handle will automatically return to the center position.

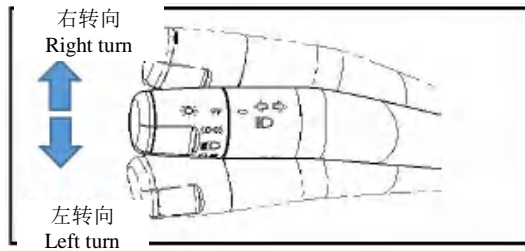

/

## Headlamp dimmer switch/passing light switch

Headlamp dimmer switch: whenever the switch handle is pulled down, the headlamp beam changes from low beam to high beam or from high beam to low beam alternately. When

the headlamp turns to the high beam, the headlamp high beam indicator on the instrument panel also lights up.

Passing light switch: when the switch handle is lifted up and put back to its original position, the high beam of headlamp can be lit intermittently. In order to send out passing signal, the switch handle should be operated repeatedly, and the high beam of headlamp should flash during the day, while the high beam and low beam should be alternately converted at night.

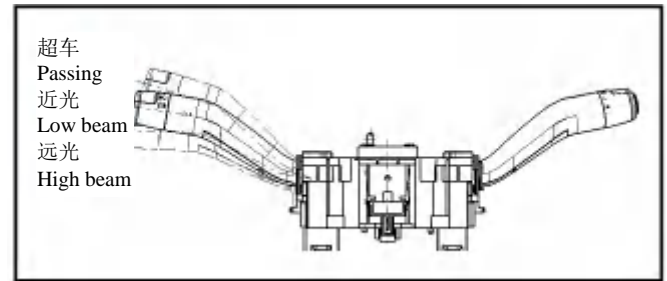

## Wiper switch

The wiper switch has four gears, turning on clockwise, OFF gear, intermittent gear, slow gear, and fast gear.

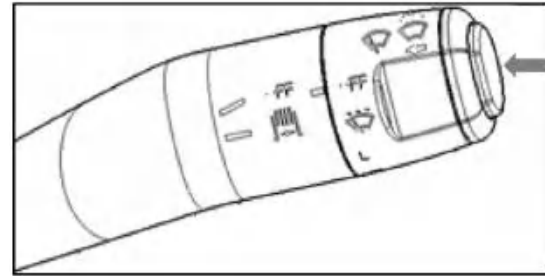
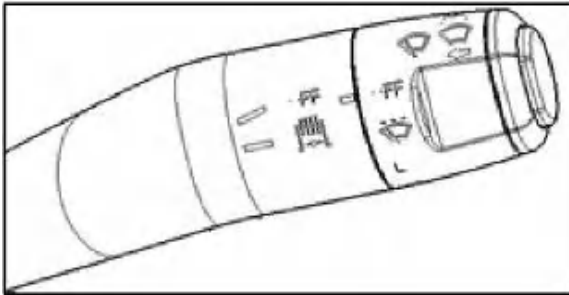

## Windshield washing switch

Press the button at the top of the switch to spray the washing liquid to the windshield, and release the button to stop.



### **Danger**



**In cold season, use defroster to heat windshield before using washer. This will help prevent icing and obstructing the driver's vision.**



### **Warning**



**If the windshield is dry, do not start the wiper to avoid scratching the glass.**



**Remove the ice and snow from the**

---

**wiper blade before using the wiper. If the ice and snow freeze the windshield, carefully loosen and remove it.**

---

### **Exhaust brake switch**

Turn on this switch, release the clutch pedal and accelerator pedal, the transmission is in the non-neutral gear, and the exhaust brake is activated. Turn this switch back and the exhaust brake is turned off.

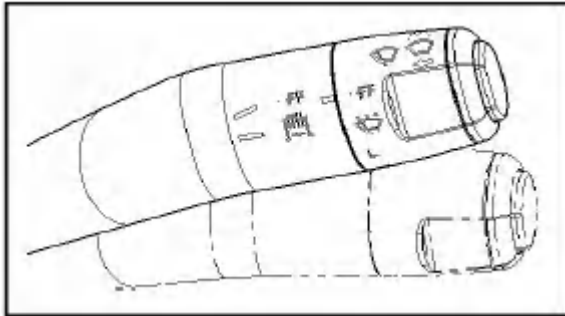

### Attention

- When driving down a long slope or in densely populated sections in mountainous areas, exhaust brake devices should be used as much as possible to avoid overheating of brake shoes and degradation of brake efficiency caused by frequent

use of brakes.

- When the exhaust brake switch is in the ON position, if the clutch pedal or the accelerator pedal is pressed, or the transmission is in neutral, the exhaust brake will automatically release or not work.

## Emergency warning light switch

When the switch button is pressed, all turn signal lamps will flash regardless of the position of the turn signal lamp switch. When the button is pressed again, the switch is turned off.



**Warning**



**When your vehicle becomes a traffic hazard during the day or night, use the emergency alarm light to warn**

---

**other drivers to pay attention.**



**Avoid parking vehicles on the highway as much as possible.**

---

## DPF manual parking regeneration and regeneration disable switch

DPF manual parking regeneration switch: when the DPF light is yellow, the driver should find a safe place as soon as possible and stop for in-situ regeneration (press DPF manual parking regeneration switch). When the DPF lamp is always red, it is important to prompt the driver to go to the service station for DPF service regeneration.



Regeneration disable switch: Press DPF regeneration disable switch in some special working conditions, such as grass, places where combustible materials are stored, or other places where high temperature of exhaust system needs to be avoided.



### Attention

- It is forbidden to turn on the "DPF regeneration disable switch" for a long time, otherwise it will cause DPF blockage.

### Electric horn change-over switch

In the state of electric horns, press the switch, switching to an air horn, and the work

indicator lights up. While in the air horn state, press the switch, switching to the electric horn.



### Attention

- Before the engine is turned off, please make sure that the air horn change-over switch is in a closed state to prevent the battery from being fed.

### Front fog lamp switch

When the ignition switch is ON, the sidelight switch is turned ON, or the headlamps are turned ON. Press the front fog lamp switch, and the front fog lamp is turned ON.



### ESC OFF switch (some models)

When the ignition switch is ON, press the ESC OFF switch, the ESC is turned off, and the instrument cluster indicator lights up at the same time

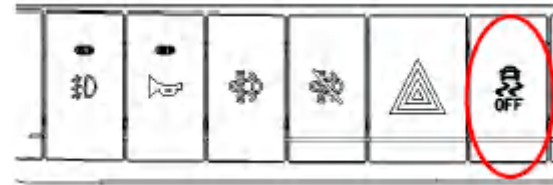

### Headlight height adjustment switch

According to the loading situation, adjust different gears to adjust the headlamp beam up and down.

### Parking brake handle

When using the parking brake, the parking brake manual valve between the seats must be pulled to the rear parking brake locked position. To release the parking brake, pull up the manual valve, and the manual valve will automatically

return to the position, and the parking will be released. At this time, if the manual valve does not return, the parking brake system indicator will light up.

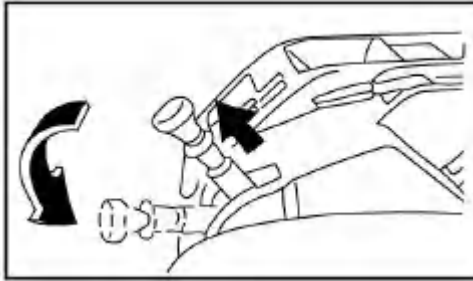

**Danger**

- The indicator has nothing to do with parking brake efficiency. When using the parking brake, pull the parking brake handle as far as

**possible.**

- If the parking brake does not work well, it will cause the vehicle to slide down the slope.

- If the parking brake handle is damaged and invalid, it must be repaired by a special service station before it can continue to be used.

## Attention

### EPB combination switch (some models)

When the ignition switch is in "ON", the indicator of EPB combination switch lights up, and the  indicator on the instrument lights up at the same time, indicating that EPB function is normal and the vehicle remains parked.

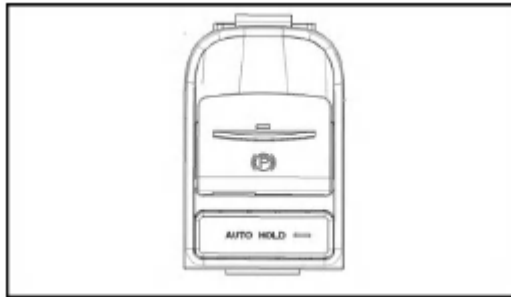

**When the AUTO HOLD indicator was turned off before the engine was shut down during the last driving, and when the engine is restarted, this function is turned off; on the contrary, the AUTO HOLD indicator is on.**

**Parking release:** when starting, engage the 1st gear, and then step on the accelerator while releasing the clutch. When the engine reaches a certain torque, the indicators on the instrument and EPB combination switch go out, the parking function is released, and the vehicle starts.

**Parking:** when the EPB function is normal, the vehicle stalls, the EPB switch indicator goes out

after being extended for 5s, and the vehicle automatically parks.

## **AUTO HOLD function**

When the AUTO HOLD function is activated, the AUTO HOLD indicator is on, and the  indicator on the instrument is on at the same time. At this time, step on the brake pedal and shift to neutral. After 3s, the vehicle automatically parks. When the AUTO HOLD function is turned off, the AUTO HOLD indicator goes out, and automatic parking cannot be realized at this time. It is necessary to pull up the switch in the EPB combination switch to complete parking.



## Manual release of parking

When you need to release the parking manually, you need to press the brake pedal and then press the EPB switch to release the parking brake.

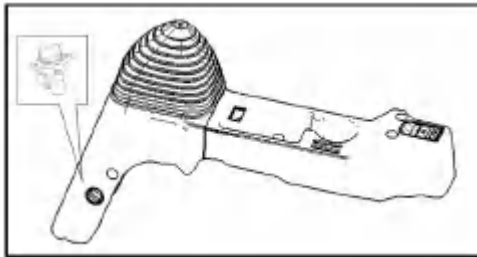

### Attention

When EPB function fails, turn the

knob switch clockwise to realize parking operation.

The knob switch is only used when the EPB function fails.



### Danger

- **AUTO HOLD**  
When reversing, turn off the AUTO HOLD function and manually

**release the parking to prevent dangerous accidents when the vehicle suddenly starts when reversing.**

EPB combination switch (some models)

When the EPB function is normal, the vehicle stalls, the indicator of EPB switch flashes for 5s and then goes out, and the vehicle automatically completes parking. When the ignition switch is on again, the indicator of EPB switch will be on, and  the indicator on the instrument will be on at the same time, and the vehicle will remain parked.

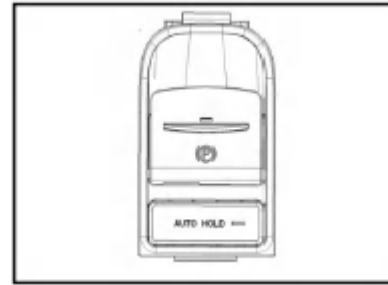

### **Attention**

- **Pull up the EPB by manual control and keep it for more than 3s. At this time, stepping on the accelerator**

**can not realize automatic release and startup, so it is necessary to manually release the EPB before startup.**

### **Flat ground/ramp startup release**

When starting, step on the accelerator. When the engine reaches a certain torque, the indicators on the instrument and EPB go out, the parking function is released, and the vehicle starts.

### **AUTO HOLD function**

When the AUTO HOLD function is activated, the AUTO HOLD indicator is on, and the  indicator on the instrument is on at the same time. At this time, after stepping on the

brake pedal for 3s, parking will be realized automatically. When the AUTO HOLD function is turned off, the AUTO HOLD indicator goes out, and automatic parking cannot be realized at this time. It is necessary to manually pull up the EPB switch to complete parking.



### **Attention**

**The AUTO HOLD function does not work when the vehicle is in reverse**

**gear.**

### **EPB function failure operation**

1. When EPB function fails, turn the knob switch clockwise to realize parking operation.
2. The knob switch is only used when EPB function fails.

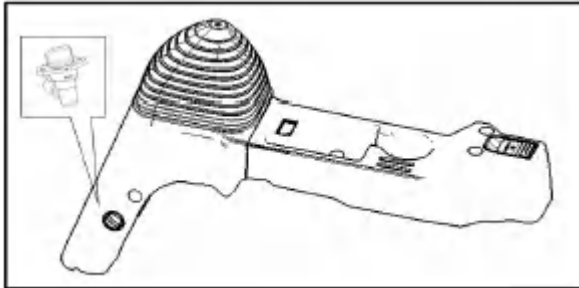

Rearview mirror heating switch (some models)

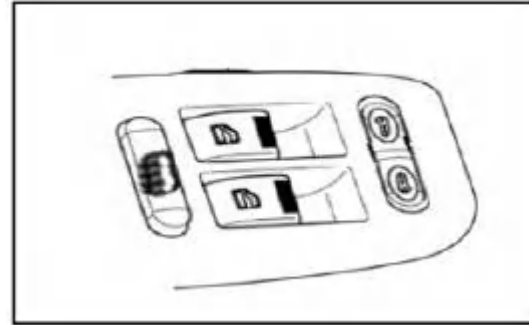

The rearview mirror heating switch is a self-reset switch. When the ignition switch is ACC, press the heating switch to heat the rearview mirror. When driving in rainy, snowy or foggy weather, the rearview mirror lenses will be covered with a layer of water mist. After turning on this switch, the heater behind the lenses can quickly heat the lenses.



### Attention

- **Do not use this function when the battery power of the vehicle is very low or the battery is faulty.**



### Cup tray

The cup tray is located near the air outlet on the left side of the instrument panel, and the wind from the air outlet heats and cools the beverage or water in the cup tray. The cup tray allows for the placement of 0.55 L ordinary mineral water bottles, but cylindrical water cups with a height greater than 215 mm must not be placed, otherwise it will affect the operation of the left handle of the combination switch.

### Ashtray

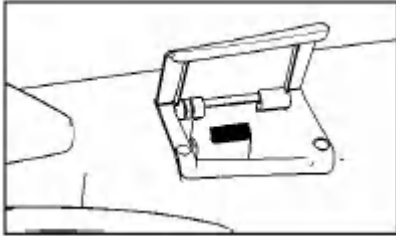

There is one on each side of the main driver and the co-driver. To use the door ashtray, open the upper cover to use it. To clean it, open the upper cover and pull out the ashtray upwards to take it out.

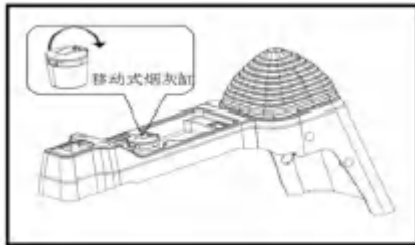

To use a mobile ashtray (if configured), open its upper cover to use. To clean it, you can directly take out the ashtray upwards.

## Power interface

The power interface is located in the middle of the instrument panel.

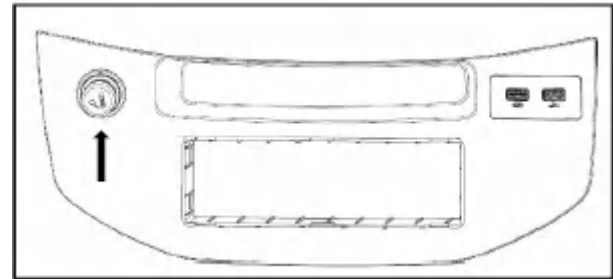

**Danger**

- **The interface power of power supply shall not exceed 200W to avoid fuse safety or fire.**

### **USB charging port**

USB charging interface is an interface for supplying power to electrical appliances other than vehicles.

The left side is the 18 W fast charging interface; the right is the multimedia data transmission interface, which supports the maximum charging current of 2.1 A.

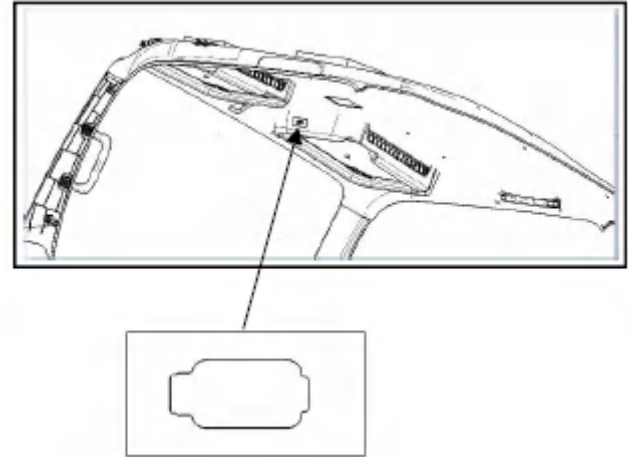

It is located in the co-driver sunshade (some models) and supports the maximum charging current of 2.1 A.

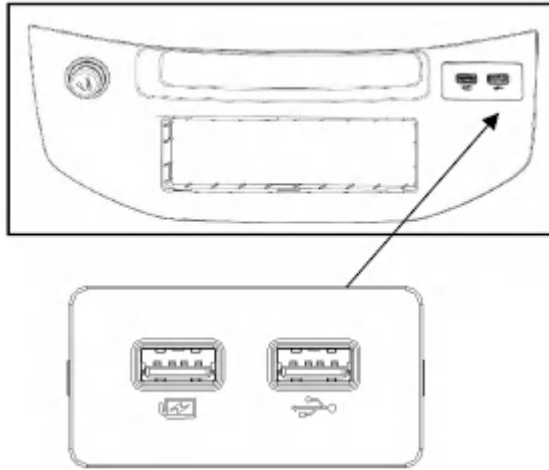

**220 V/AC on-board power supply system (some models)**

**-300 W on-board power supply system**

**The rated power is 300 W/220 V, and overload is not allowed in actual work.** The power socket is located in the cab, and its specific shape and position are shown in the following figure. Under normal circumstances, the ignition switch is placed in ACC gear, the power supply can be turned on, and the indicator is green; when the battery voltage of the vehicle is abnormal, the power supply is turned off, the indicator is yellow, and the power supply system can be automatically restored after the voltage is normal. When the electrical equipment is overloaded or faulty, the power supply is in a protected state and turned off, and the indicator is red. Because the fault is in a protected state, you can turn off the ignition switch and re-power it to try to recover.

**-1000 W on-board power supply system**

**The rated power is 1000 W/220 V, overload is not allowed in actual work, and the on-board power supply is allowed only**

**after the engine starts.** The power socket is located in the cab, and its specific shape and position are shown in the following figure. Under normal circumstances, the power-on indicator is green; when the electrical equipment is overloaded, the indicator flashes in red; when the electrical equipment is faulty, the power supply is turned off in a protected state, and the indicator is always red. Because the fault is in a protected state, you can turn off the ignition switch and re-power it to try to recover.

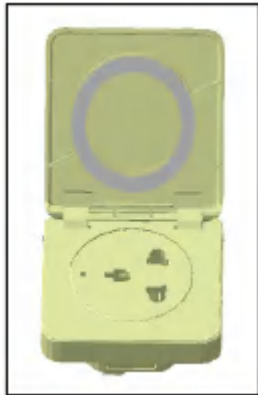

:

Special reminder: for the following types of electrical equipment, the power supply may not work normally;

1. Equipment with high initial peak wattage, such as refrigerators driven by compressors and electric tools;

2. Electrical equipment with special requirements for the stability of AC output voltage, such as electric blanket controlled by microcomputer, touch induction lamp, etc.

3. Power strip. Power socket position varies depending on vehicle model, subject to actual vehicle

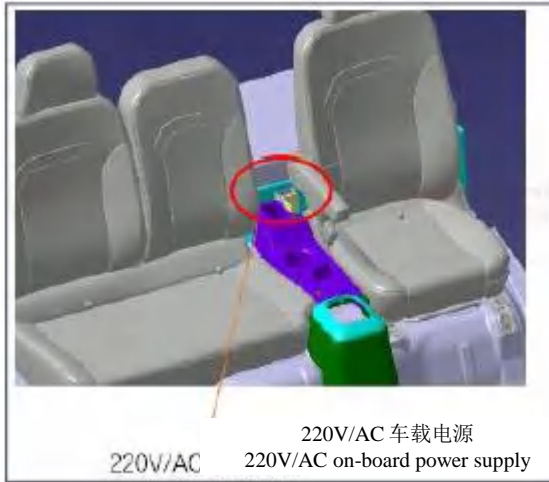

### Attention



**After the engine is turned off, long-term use will lead to battery power loss and affect starting!**

## Charging power interface (some models)

The charging power interface is located on the battery side of the chassis, as shown in the following figure.



Wiring requirements:

The positive (+) of the charging equipment is connected with the pole of the power switch, and the fastening torque is 41 N.m–50N.m;

terminals must be matched with protective caps of corresponding size for insulation protection; the harness is fixed reliably, so that the harness does not squeeze, rub against the tough edge or pull too tightly.

The negative (-) in the frame to find a suitable hole position to paint the ground nearby. When connecting the ground wire on the frame, paint must be scraped, and the pile head of the wire must be coated with industrial vaseline and assembled with bolts, nuts and other parts.

### Precautions:

1. The negative (-) grounding point shall not be placed together with the grounding point of the ECU or ABS.

2. In order to ensure safe operation, disconnect the negative (-) of the battery and

ensure that the power switch is OFF.

3. It is forbidden to plug and unplug electrical equipment with electricity.

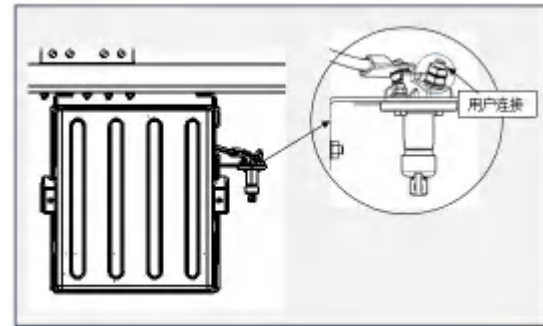

用户连接  
User connection



### Attention

●  
**The safe capacity of charging circuit is 80 A, and excessive charging**

**current will cause the fuse.**



**The positive (+) shall be insulated.**



**When the connected electrical equipment is not in use, the power switch shall be turned off in time to avoid battery power loss.**

### **Mobile phone support (some models)**

The mobile phone can be placed on the mobile phone support, which is convenient to operate the mobile navigation.

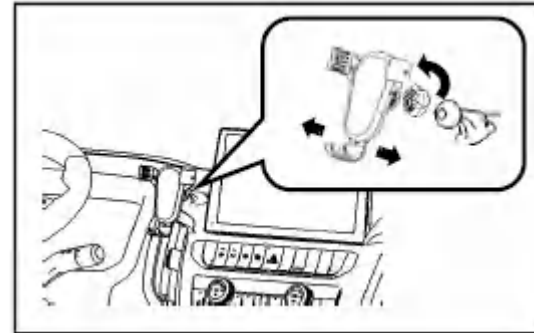

By rotating the knob on the back of the mobile phone support to the right, loosen the mobile phone support, adjust the support to a comfortable angle for operation, and rotate and tighten the knob to the left.

### **Shift lever (MT model)**

1. Whenever shifting operation is carried out, the clutch pedal should be pressed to the bottom in

advance.

2. The shift position diagram is located above the ball head of the shift lever.

3. When the shift lever is turned to reverse with the start switch key in the "ON" position, the reverse indicator will light up.

4. If a reversing radar is installed, when shifting to reverse gear, the radar probe detects the obstacle information within 1.8 meters behind the vehicle and transmits it to the radar controller, which gives a buzzer alarm.

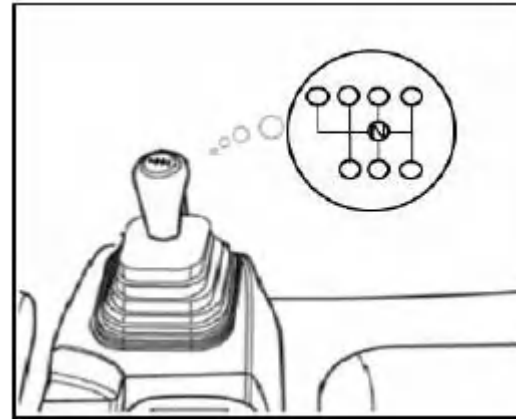

### Attention

● **The vehicle must be stopped completely before shifting to reverse gear.**

# Gear setting

The gear setting is engraved on the shift handle

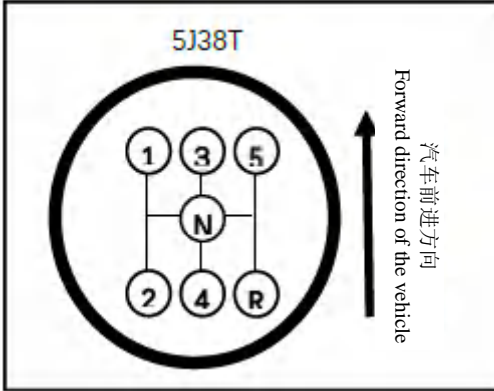
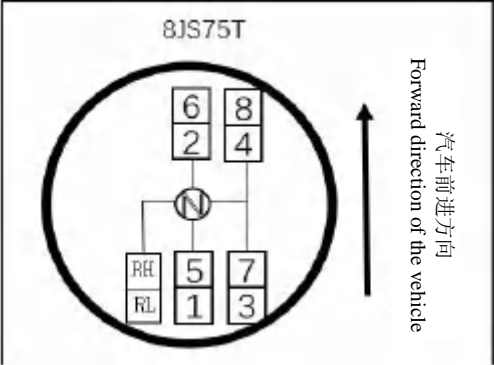
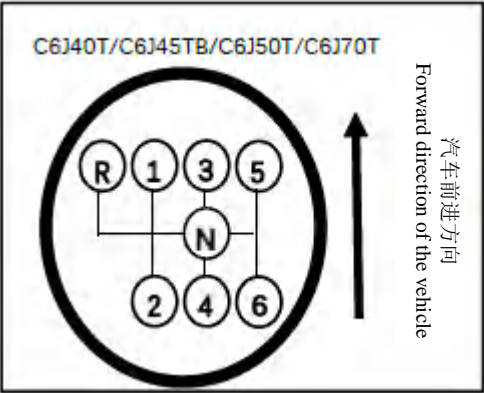

## Accelerator pedal

To avoid unnecessary fuel consumption, the accelerator pedal should be operated properly and smoothly as needed.

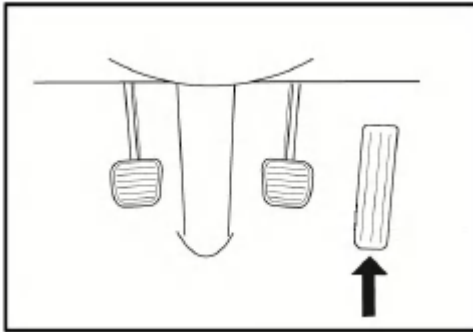

## Brake pedal

To avoid sharp braking, depress the brake

pedal smoothly.

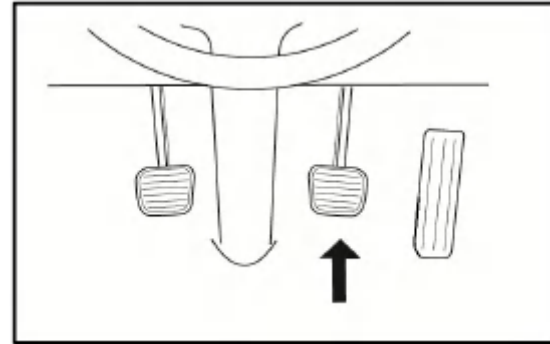

When driving down a long slope, it is recommended to use the engine-assisted brake. If necessary, step on the brake pedal with your feet.

## Clutch pedal

To disengage the clutch, the clutch pedal must be pressed to the bottom, otherwise the

friction plate is in a semi-disengaged state, which may lead to rapid wear.

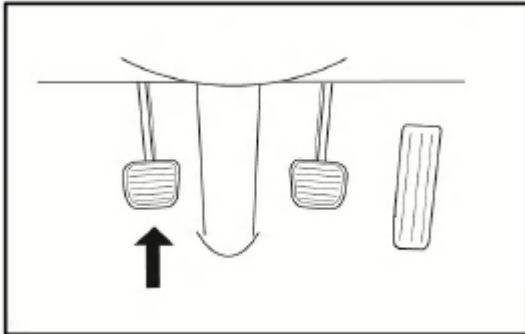



## Attention

● **Do not put your feet on the clutch pedal when not using the clutch.**

### Shift lever (AMT model)

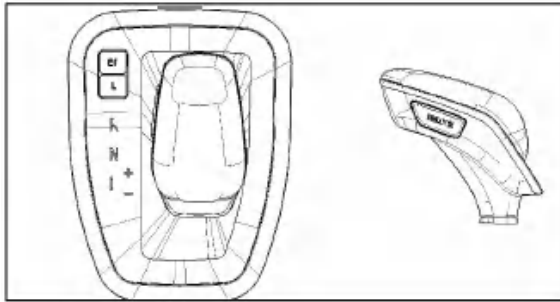

### Driving mode switch button (EP):

Default economic model: press the "EP" button to switch to power mode, while the "P" indicator on the instrument is on, then press it to return to economic mode, while the "P" indicator on the instrument is off; press this button, the system will switch between these two modes in cycle.

**Manual mode:** move the shift lever to the right in D gear, move the shift lever to "+" or "-" position. Manually control + and - gear, and the instrument panel displays the forward gear position as "M1–M6".

**Creep button (L):** press the "L" button after engaging into D gear, the instrument displays Dm, press the accelerator pedal to realize the slow movement of the vehicle, then press the instrument to display D1 or D2, press the "L" button after engaging into R gear, the instrument displays Rm, press the accelerator pedal to realize the slow movement of the vehicle, and

then press the instrument to display R. This function can realize the slow movement of the vehicle or the slow approach to the unloading platform. When the road slope is  $\geq 5\%$ , this function does not work

**Reverse lock button (UNLOCK):** this button needs to be pressed when switching reverse gears.

### Storage box

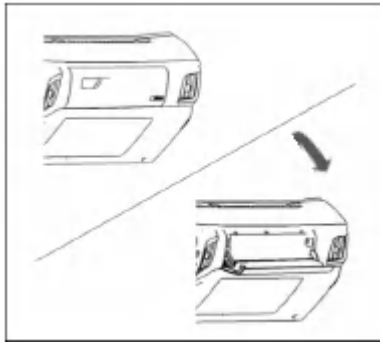

The storage box is located at the right end of the instrument panel. Pull outward the handle on the upper part of the storage box on the assistant side of the instrument panel end to open the storage box.



### Danger

● **It is important to avoid opening the storage box when driving, otherwise, when braking suddenly or encountering unexpected situations, the objects in the storage box may jump out and hurt people.**

### Sunshade

If the sun shines head-on to dazzle, the

sunshade can be put down to block the sun.

Push the hook out of the base and rotate to the side to a suitable position to block the side sunlight.

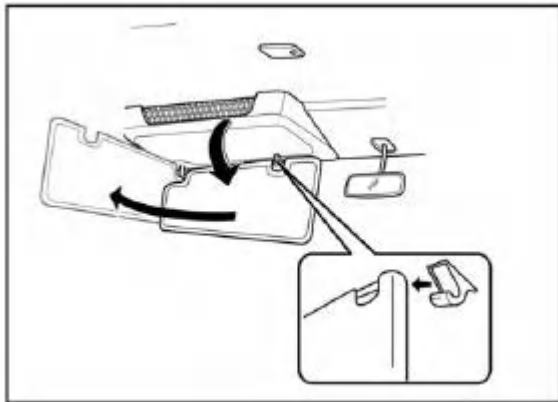

## Ceiling lamp

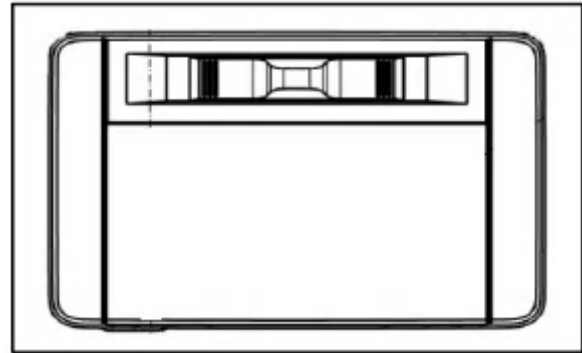

The ceiling lamp can be operated regardless of the position of the ignition switch.

1 "OFF" position: The ceiling lamp is off.

2 "Door" position: when the door on either side of the driver and the co-driver is opened, the ceiling lamp will light up for 15s and then automatically go out.

3 "On" position: No matter what state the door is in, the ceiling lamp will light up.



### Attention

● **When the ceiling lamp switch is placed in the "door" position, make sure that the door is completely closed to prevent the ceiling lamp from burning all the time and causing the battery to consume power.**

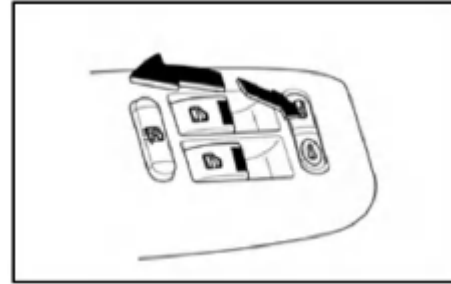

The power window main switch is located on the driver's door trim panel, and the driver can control the lifting of the door glass on both sides. In addition, the passenger side has a corresponding window sub-switch.

### Automatic lower

Power window glass lifting

**Power window main switch**

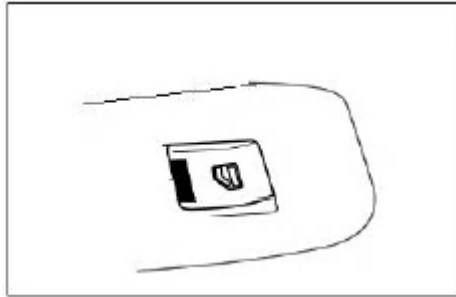

The driver's side window has a one-button lower function, and lightly pressing and heavily pressing the switch correspond to inching lower and one-button lower respectively. Lift the switch upwards to lift the window glass, and short lift the switch to realize inching lift.

### **Power window sub-switch**

The power window sub-switch is located on the passenger door trim panel and can only

control the passenger door glass to lift and lower.

Lightly pressing and lifting the switches correspond to inching lower and inching lift functions respectively.



### **Attention**

**The ignition switch must be turned on to use the power window. The driver has the responsibility to inform passengers of the relevant operation of the elevator to prevent accidents. Please close the windows when leaving the vehicle.**

## Windshield washer reservoir

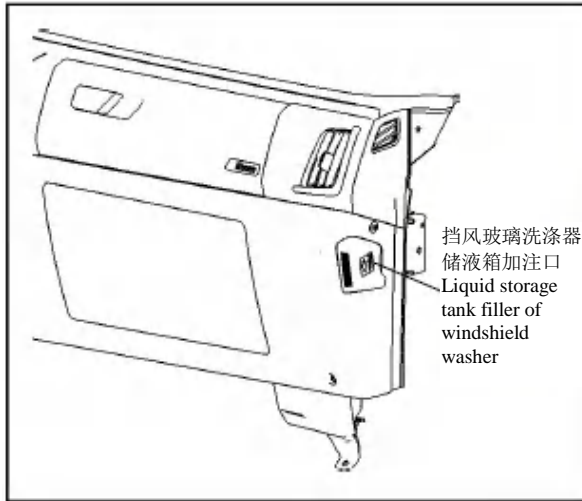

The windshield washer reservoir is installed under the instrument panel on the passenger side.



### Attention

- **It is forbidden to add unclean water to the washer, so as not to block the nozzle of the washer.**

In order to ensure the normal operation of the washer, please add the standard washer liquid, which is 50% methanol (or isopropanol, ethylene glycol) aqueous solution. If pure water is added, it may cause the wiper to scratch uncleanly.



### Warning

- **Do not use radiator antifreeze in washer reservoir, otherwise it may**

---

cause damage to paint surface.



Remove the ice and snow on the wiper blade before using the wiper.



**Washer liquid requirements: water with hardness lower than 205g/t, and add proper amount of antifreeze.**

---



**Danger**



**In cold seasons, use a defroster to heat the windshield before using the washer. This will help prevent from icing and obstructing the driver's**

**sight.**

### **Clutch oil storage cup**

The oil storage cup is installed on the inside of the driver-side instrument panel.

### **Fuel tank filler cap**

Open the cover plate and unlock or lock it with a key.

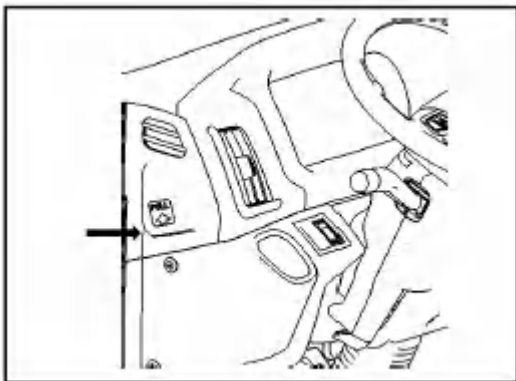

### Attention

- To ensure the service life of the oil tank cap, please regularly add a small amount of grease to the rotating part of the oil tank cap and lock.

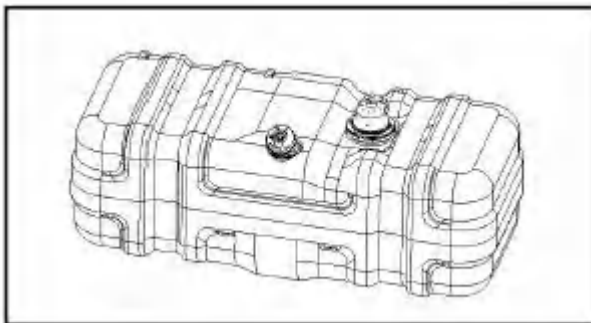

## Spare tire hanger

The spare tire is fixed to the rear of the frame with a chain. To use the spare tire, first turn the spare tire locking nut counterclockwise and loosen it, then insert the wrench on the spare tire rocker, and then turn it counterclockwise.

To lift the spare tire, rotate the spare tire rocker clockwise to the end, then further twist and lock it tightly, and then rotate the spare tire locking nut clockwise to tighten, so that the spare tire is firmly fixed in the storage position.

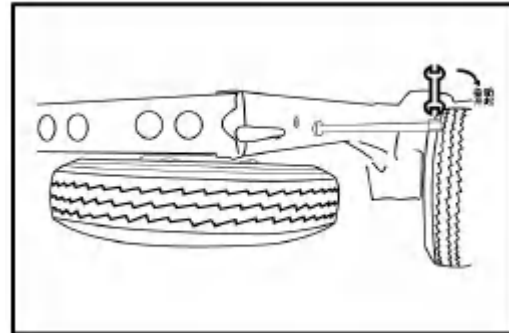
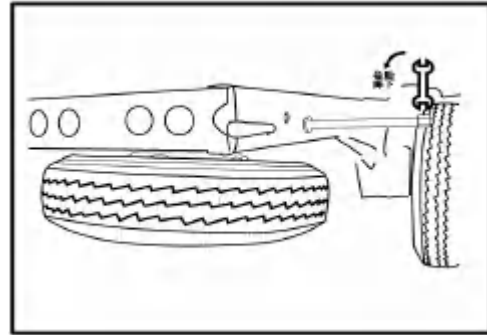

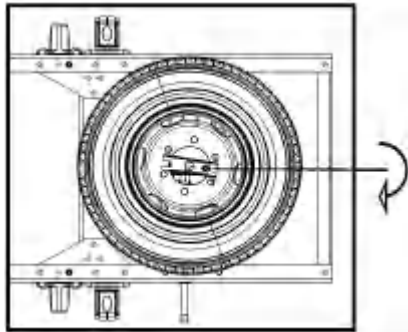
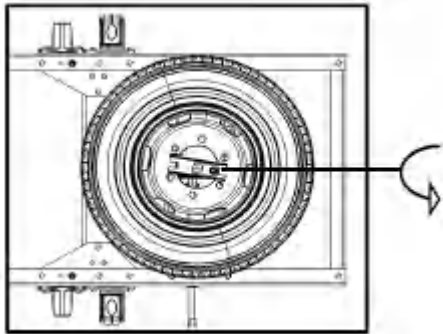

## Danger

- In order to prevent the danger caused by sudden braking or accident, the spare tire must be firmly fixed in the storage position.

External lights

Front combination lamp/front fog lamp (left and right symmetrical)

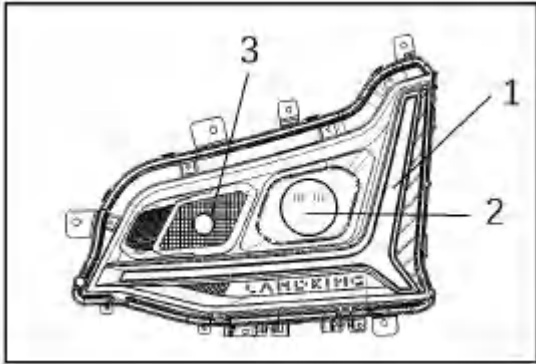

1 Day running lamp and steering indicator.

2 High/low beam

3 Auxiliary high beam

### Combined rear light

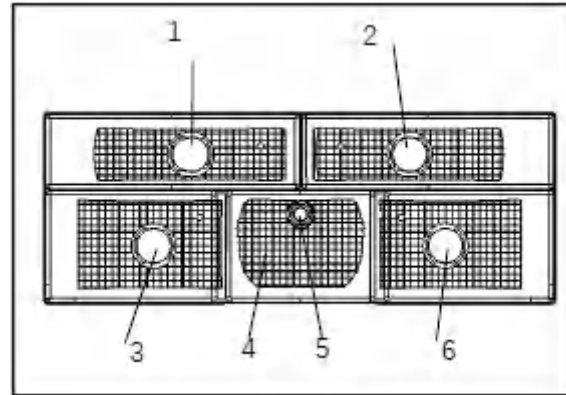

1. Rear turn signal lamp

2. Reversing lamp

3. Brake lamp

4. Rear retro reflector

5. Rear position lamp

6. Rear fog lamp

## Heating device, demister, defroster, air conditioner

According to the operation of the button or knob on this panel, the wind direction, wind force, setting temperature and internal and external circulation state of the whole air conditioning/heating system can be controlled.

The positions of each air outlet are shown in the figure:

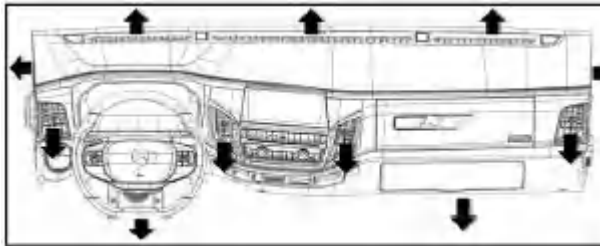

## Air conditioner panel (heater, defrost, dehumidification, air conditioner panel)

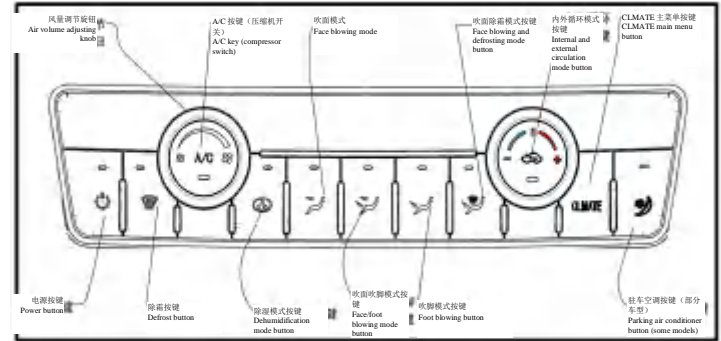

Among them: internal and external circulation buttons (in external circulation mode when green indicator lights up).

## Temperature control knob

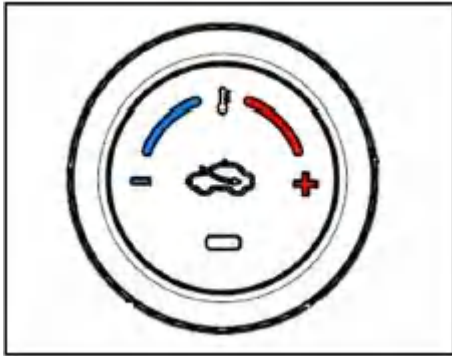

Rotate this button to control the air outlet setting temperature. Rotate to the left to reduce the setting temperature gradually, while rotate to the right to increase the setting temperature gradually. Rotate clockwise, the highest setting temperature is HI. Rotate counterclockwise, the lowest setting temperature is LO. The temperature increases or decreases by 1 °C, with a maximum of 32 °C corresponding to HI and a minimum of 18 °C corresponding to LO;

The setting temperature is HI, force the air volume to 7 gears, external circulation and A/C off;

The setting temperature is LO, force the air volume to 7 gear, internal circulation, A/C on.

### Air volume control knob

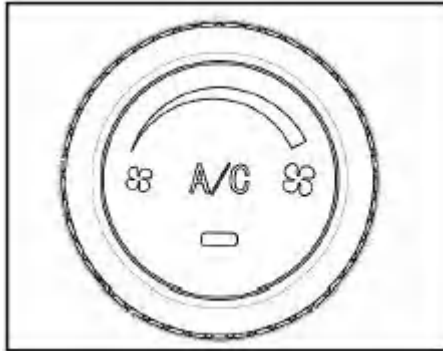

Use the air volume control knob to turn on or off the fan and adjust the wind speed. Rotating clockwise can increase the wind speed, while rotating counterclockwise can reduce the wind speed.



### Blowing mode selection button

Use the blowing mode selection button to manually select the blowing mode.

Face blowing mode: press this button to switch the mode damper to the face blowing position, and the air flow is discharged from the face blowing outlet of the instrument panel.



Face blowing and foot blowing mode: press this button to switch the mode damper to the face

blowing/foot blowing position, and the air flow is discharged from the middle, side and floor air outlets of the instrument panel.



Foot blowing mode: press this button to switch the mode damper to the foot blowing position, and the air flow is mainly discharged from the floor outlet.



Defrosting and foot blowing mode: press this button to switch the mode damper to the small defrosting position of foot blowing, and the air flow is discharged from the defrosting grille and the air

outlet above the floor.



Defrost mode: press this button to switch the mode damper to defrost position. Air flow is discharged from defrost grille.



One-button dehumidification mode: press this button to switch the mode damper to the dehumidification position, and the indicator will be on. The airflow is discharged according to the button of blowing mode. A/C is started forcefully.

### Internal and external circulation keys



This button can control the intake of external air and the circulation of internal air. When the indicator is on, it is external circulation, and when the indicator is off, it is internal circulation. Switch the state every time you press the button.

:

The internal circulation mode is used for driving on dusty roads to prevent exhaust gas from the cab and strong cold air from entering the cab.

### **Power button**



Power button: press this button to control the opening and closing of air conditioning ventilation and compressor. When the air conditioning system is working, press the button to stop the air conditioning ventilation and the compressor. In the shutdown state, press the button again to start up the air conditioner. According to the A/C and air outlet mode before shutdown, the air conditioner run at the setting temperature. The air volume will default to 1st gear when starting the air conditioner through the power button.

### **Main menu switch button**



Press the "CLIMATE" button, and MP5 switches to the main menu of air conditioner. After switching to the air conditioner main menu, switch to the target main menu when MP5 has other menu request commands.

Note: this button only supports MP5 model configuration, vehicles with MP3 model can ignore this button function.

### **Switching between internal and external circulation mode**

In order to take care of users' needs of external circulation ventilation during the long-term use of internal circulation. Every time the air conditioner turns on the default internal

circulation (whenever the internal circulation exceeds 45 min, it automatically switches to the external circulation for 1 min (the indicator remains unchanged), and then switches to the internal circulation to ensure the fresh air in the car.

1. When the setting temperature is HI: the internal and external circulation mode forces external circulation, and A/C is closed.
2. When the setting temperature is LO, the internal and external circulation mode forces internal circulation, and A/C is turned on.
3. No matter what the setting temperature value is, whether the air conditioner is on or not, the internal and external circulation can be adjusted by the user.

### **Defrosting**

This mode is used to remove frost from windshield.

1. Put the internal and external circulation buttons in the external circulation mode.
2. Set the air outlet selection button to defrosting mode.
3. Adjust the wind speed knob to the maximum wind speed.
4. Adjust the temperature knob to the maximum gear.
5. When the frost on the windshield does not affect the visual field, it can be adjusted to the original mode and the wind speed and

temperature can be lowered.

### **Heating and defogging**

This mode is used for internal heating and windshield defogging.

1. Put the internal and external circulation buttons in the external circulation mode.
2. Adjust the air outlet selection button to defrosting and foot blowing mode.
3. Adjust the wind speed knob to the required wind speed.
4. Adjust the temperature knob to the corresponding gear.



### Attention

- **Do not use the internal circulation mode for a long time when parking, otherwise the air inside the car will be turbid and the windows will be fogged.**

- **If you need to run in internal circulation mode for a long time, it is recommended to switch to the external circulation every 45 minutes or so and then switch back to the internal circulation for 2–3 minutes.**

### Operation of air conditioner

Start the engine, adjust the air volume control knob to the required gear, and press A/C (compressor switch) to start the air conditioner. When the air conditioner is turned on, it will have refrigeration and dehumidification functions. If you need to turn off the air conditioner, press the power button directly.

### Refrigeration

This mode is used when refrigeration is required.

1. Put the internal and external circulation buttons in the internal circulation mode.
2. Adjust the air outlet selection button to the face blowing mode.

3. Adjust the wind speed knob to the required wind speed.
4. Press A/C (compressor switch), and the indicator will light up.
5. Adjust the temperature knob to the corresponding gear.
6. When the temperature inside the car drops to the comfort zone, it can be adjusted to the external circulation mode.

### **Air conditioner dehumidification**

The air conditioner panel is equipped with a dehumidification button. When dehumidification is required, the dehumidification button can be

directly pressed, and the blowing mode can be adjusted to the face blowing mode. When dehumidification mode works, the default internal and external circulation state is internal circulation. Forcibly start the compressor, and the setting temperature is automatically adjusted according to the water temperature.

### **Air conditioner operation skills**

1. When the weather is hot, open the window and drive for 2–3 minutes, and then close the window after removing the hot air in the cab. This is helpful to shorten the time required for vehicle refrigeration and improve the operation efficiency of the system.

2. All windows shall be closed when the air conditioner works.

3. Turn on the air conditioner for at least 10

minutes every month (when the outside temperature is higher than 5 °C) to prevent the air conditioning system from being damaged due to poor lubrication.

4. If the coolant temperature indicator is on, please turn off the air conditioner.

5. If the engine coolant reaches extremely high temperature, the air conditioning system will automatically shut down.



### Attention

● Sometimes you will find mist at the air outlet, which does not mean fault. It is the mist produced when

the high temperature and high humidity air cools rapidly. When the outside temperature is very high and you want to cool down quickly, you can choose the internal circulation mode. In order to prevent the window from fogging and the air turbidity in the car, you can return to the external circulation mode in time and press the internal circulation mode again.

● When the vehicle is parked in a garage or a place with poor air circulation, the air circulation mode should be turned on to avoid poisoning danger caused by air entering the vehicle.

● Turn off the air conditioner before

parking.

● Within 3 months of purchasing a new vehicle, when using the air conditioner, avoid sudden acceleration to ensure that the compressor starts the running in period.

● Don't smoke in the vehicle with the air conditioner on.

Multimedia

MP5 assembly (some models)

## 1. Desktop

### 1.1 First screen of application center



1. Click to enter the navigation interface.

2. With Bluetooth or USB connection, click to enter the music player.

3. Click to enter the radio playback interface.

## 1.2 Application center - second screen

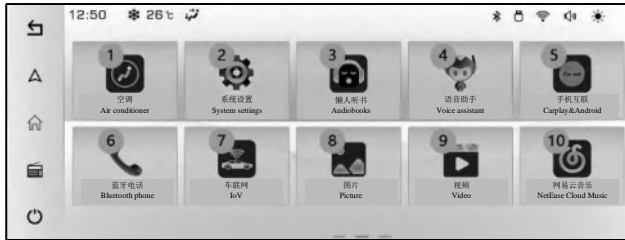

1. Click to enter the air conditioner interface.
2. Click to enter the system settings.
3. Third-party application, click to enter the Audiobooks.
4. Enter the voice assistant function.
5. Third-party application to realize mobile

phone interconnection.

6. In Bluetooth connection state, click to enter the dial keyboard interface.

7. Third-party application, click to enter the Internet of Vehicles.

8. When the USB device is connected, click to enter the picture view.

9. When the USB device is connected, click to enter the video viewing.

10. Third-party application, click to enter NetEase cloud music.

## 1.3 Application center - third screen

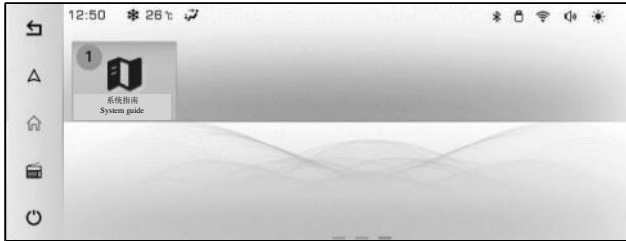

**1.4**

**1.4 Navigation bar**

1. Click to enter the system guide.



1. Light up and return to the previous operation interface. When there is no previous operation,

click not to return, only the button prompts the effect.

2. Click the navigation shortcut button to enter the memory interface when exiting last time. If each ignition cycle enters for the first time, it will start from the detection page.

3. Click to enter the first screen of the application center

4. Click the radio shortcut button to enter the memory interface when exiting last time. If each ignition cycle enters for the first time, it will start from the detection page.

5. Click the screen extinguish button to enter the screen saver interface.

## **1.5 Underline the notification bar**

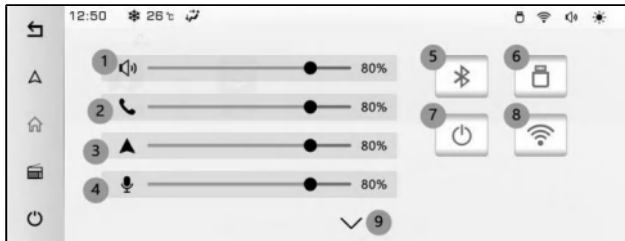

1. Slide the progress bar to adjust the volume of the media.

2. Slide the progress bar to adjust the volume of Bluetooth calls.

3. Slide the progress bar to adjust the navigation volume.

4. Slide the progress bar to adjust the voice volume.

5. Click to quickly turn Bluetooth on or off.

6. Displays the current USB status.

7. Click to turn the air conditioner on or off quickly.

8. Click to quickly turn WIFI on or off.

9. Click the button notification bar to quickly return to the current page.

## **1.6 Overline the background application process**

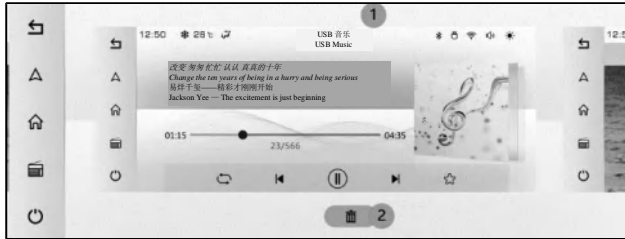

1. Drag up to the top to delete the application process.

2. Click the button to delete all background applications.

## 2. Air conditioner



1. Display air conditioning temperature.

2. Display air conditioning wind speed.

3. Display the on/off of the foot blowing mode.

4. Display the on/off of the head blowing mode.

5. Display the on/off of the head/foot blowing mode.

6. Display the on/off of the defogging and foot blowing mode.

7. Display the on/off of the defogging mode.

8. Display the on/off of the air conditioner.

9. Display the on/off of the refrigeration.

10. Display the on/off of the internal and external circulation switching.

11. Display the on/off of the dehumidification mode.

12. Display the on/off of the defrosting mode.

## 3. Music

### 3.1 Music Interface



1. When the USB device is connected, click to enter USB to play music.

2. In the Bluetooth connection, click to enter Bluetooth to play music.

3. Play the music list when plugged into USB or connected Bluetooth.

4. Play the list of favorite music in the current state.

5. Search for songs in the current music list.

6. Enter the music playing interface.

### 3.2 Music play interface

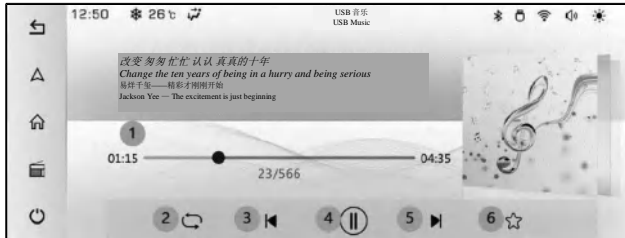

1. Click or drag the progress bar to adjust the play progress.

2. Click to switch the play mode, including random play, single loop and list loop.

3. Click to play the previous song.

4. Click to pause the music or continue to play.

5. Click to play the next song.

6. Click to collect or cancel to collect the current music.

### 3.3 Bluetooth music play interface



1. Click or drag the progress bar to adjust the play progress.
2. Click to play the previous song.
3. Click to pause the music or continue to play.
4. Click to play the next song.

## 4. Radio

### 4.1 Local station play interface



1. Click to switch AM or FM mode.
2. Click to search the station.
3. Click to switch to the previous station.
4. Click the radio station to pause or continue playing.

5. Click to switch to the next station.

6. Click to collect the station.

7. Click to pop up the station favorite list interface.

8. Slide the station manually.

### 4.2 Local station play interface



1. Favorite list, long press to pop up the pop-up box for deleting favorite stations.

### 4.3 Deletion of favorite local stations



1. Click confirm to delete the current favorite station.

2. Click cancel to cancel the deletion of the current favorite station and return to the station play interface.

## 5. Bluetooth phone

### 5.1 Bluetooth phone interface



1. Click to enter the dial keyboard interface.

2. Click to enter the call record interface.

3. Click to view the address book interface.

4. Click the numeric keypad to dial.

5. Click the Delete button to delete the number.

6. After dialing, click to call.

### 5.2 Bluetooth phone call interface



5. Click Mute or Unmute.

6. Click to hang up.

1. Click to answer the phone.

2. Click to hang up.

3. Click to switch between vehicle or Bluetooth to answer.

4. Click to enter the dialing interface of numeric keyboard.

## 6. Pictures



1. Rotate the picture 90 °clockwise.
2. Click to switch to the previous viewable picture.
3. Click to start or pause the picture slideshow.
4. Click to switch to the next viewable picture.

## 7. Video



1. Play the current video in full screen.
2. Click to switch to the previous playable video.
3. Click Pause or Play the video.
4. Click to switch to the next playable video.

5. Drag or click the progress bar to control the play progress.

## 8. System settings



1. Click to enter Bluetooth settings; connect Bluetooth, set up automatic answering and automatic connection.

2. Click to enter the wireless network settings; connect to WIFI.

3. Click to enter the sound settings; set touch prompt tone, adjust media, navigation volume, call volume, voice volume, sound effect and sound stage volume.

4. Click to enter the general settings; set system language, screen brightness, time and date.

5. Click to enter the restore operation settings; restore system or vehicle settings and clear everything.

6. Click to enter the system information settings; view system version information, etc.

## 8.1 Bluetooth setting interface



1. Click the slider at the bottom of the box to turn on or off Bluetooth.

2. Click the slider to turn on or off the automatic answering function.

3. Click the slider to turn on or off the automatic connection function.

4. Display the Bluetooth name of the current device. Click to modify the name.

5. Refresh the button and click to search for Bluetooth devices that can be paired and connected around.

6. Click this button to connect the current Bluetooth device.

7. Click this button to delete the paired Bluetooth device.

## 8.2 Wireless network setting interface



1. Click the slider below to turn on WIFI function.
2. Click the Disconnect button to disconnect the current network.
3. Refresh the list button, and click to refresh the currently searched device.
4. Click the Connect button to connect to the current network.

### 8.3 Sound setting interface

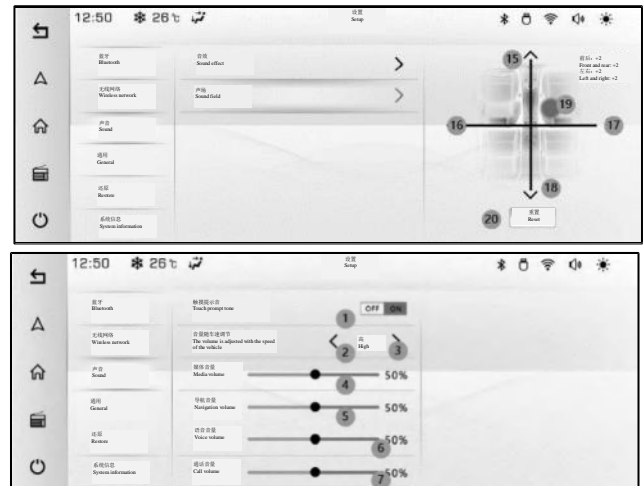

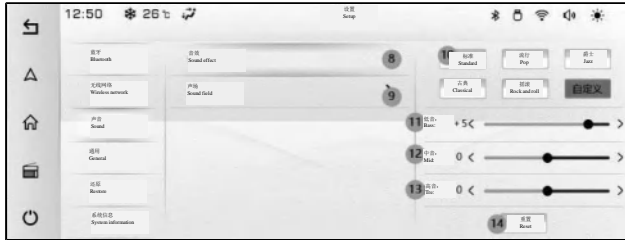

1. Click the slider below to turn on or off the touch tone.

2.3. Click this button to adjust the volume corresponding to this function.

4. Drag the slider to adjust the volume of the media.

5. Drag the slider to adjust the navigation volume.

6. Drag the slider to adjust the voice volume.

7. Drag the slider to adjust the volume of the call.

8. Click the button to enter the sound effect interface.

9. Click the button to enter the sound field interface.

10. Click the button to enter the button sound effect mode.

11. Click the buttons on both sides or drag the slider to adjust the bass sound gain.

12. Click the buttons on both sides or drag the slider to adjust the mid sound gain.

13. Click the buttons on both sides or drag the slider to adjust the treble sound gain.

14. Click the button to restore the sound settings to the factory settings.

15. Click the button to move the sound field slider upward.

16. Click the button to move the sound field slider to the left.

17. Click the button to move the sound field slider downward.

18. Click the button to move the sound field slider to the right.

19. Drag the slider to adjust the sound field

position.

20. Click the reset button to return the sound field adjustment slider to its original position.

## 8.4 Universal setting interface





1. Click the button to enter the language setting interface.

2. Click this button to set the corresponding brightness mode.

3. Drag the slider to adjust the brightness.

4. Click the button to enter the date and time setting interface.

5. Click the button to select Simplified Chinese mode.

6. Click the button to select English mode.

7. Click the button to enter the 24-hour mode.

8. Click the button to enter the 12-hour mode.

9. Click to turn on or off the automatic time setting function.

10. Click the button to pop up the time zone setting box.

11. Click the button to pop up the time and date setting box.

12. Click the button to select different models.

## 8.5 Restore setting interface



1. Restore all user data to default values.

## 8.6 System information interface



1. Display the version information of the system, including hardware version; the version of the operating system; MCU software version.

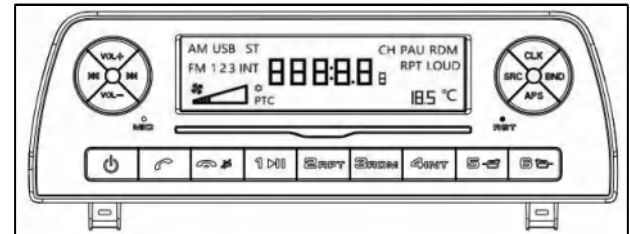

**MP3 assembly (some models)**

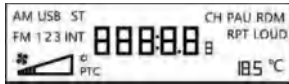

Display radio frequency band, USB music status indication, Bluetooth status indication, air conditioner setting temperature, setting wind speed and other information.



Press and restart the radio.

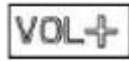

Click to increase volume by 1, long press to continuously increase volume by 1, and click is invalid when volume is 40.

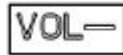

Click to decrease volume by 1, long press to continuously decrease volume by 1, and click is invalid when volume is



00.

In radio mode, click radio band to decrease 0.1 MHz, long press 2s to automatically search for the previous effective station; in music mode, click the previous music, long press is invalid.



In radio mode, click radio band to increase 0.1 MHz, long press 2s to automatically search for the next effective station; in music mode, click the next music, long press is invalid.



Click to display the current setting time, click continuously the time display to switch the current mode continuously, and long press is invalid. In the time display state, long press for 2s to enter the time setting, and adjust the time through the

volume +/- button.



Click mode switch, long press is invalid. Unconnected USB flash disk status: radio-Bluetooth mode switching; connected USB flash disk status: radio-USB-Bluetooth mode switching.



Click to enter the radio band page to switch, and long press is invalid. FM1-FM2-FM3-AM1-AM2 cycle switching.



Radio mode: click to enter the state of automatic station search, and long press is invalid. Music mode: click/long press is invalid.



Turn on ACC to automatically turn on MP3, press long for 2s to turn off MP3, and click on

MP3 again



In Bluetooth connection status, click to answer the call. Click/long presses is invalid in other status.

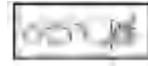

In Bluetooth connection status, click to hang up the call. Click/long press to enter mute/non-mute switch.

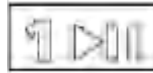

In radio mode, click to enter the first storage station on the current page; in music mode, click to enter play/pause state switch; in the pause status, the display shows PAU indication, click Cancel again, long press is invalid.



In radio mode, click to enter the second storage station on the current page; in music mode, click to enter single play

state switch; in the single play status, the display shows RPT indication, click Cancel again, long press is invalid.



In radio mode, click to enter the third storage station on the current page; in music mode, click to enter random play state switch; in the random play status, the display shows RDM indication, click Cancel again, long press is invalid.



In radio mode, click to enter the fourth storage station on the current page; in music mode, click to enter play viewing state switch; in the play viewing status, the display shows INT indication, click Cancel again, long press is invalid.

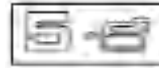

In radio mode, click to enter the fifth storage station on the current page; in music mode, click to select next ten songs; and if there are less than 10 songs, play the first song; long press is invalid.



In radio mode, click to enter the sixth storage station on the current page; in music mode, click to select previous ten songs; and if there are less than 10 songs, play the first song; long press is invalid.

## **Before driving**

### Operation of various controllers

Correct maintenance and careful driving can not only keep the vehicle in good technical condition, prolong the service life of the vehicle, but also improve the use economy of the vehicle.

#### Key

This key is used to operate ignition switch, door lock and fuel tank cap. Please keep it properly. Each key is engraved with a code plate. Please record the code plate of the key and keep it in a place where it is not easy to lose. Do not put it in the vehicle.

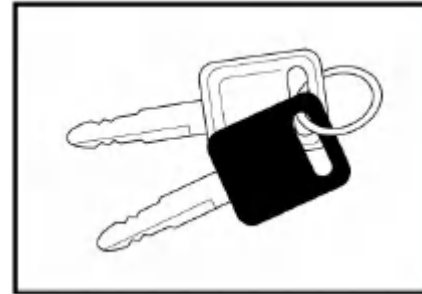

#### **Ordinary key**

#### **Remote control key**

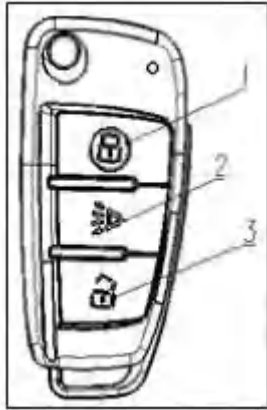

1. Remote control locking function: press the remote control locking key under normal circumstances, all doors are locked and all turn signal lamps flash once. Long press the locking function to remotely control doors and windows to automatically rise to the top, and all turn signal lamps flash twice. 2. Vehicle search function: when the vehicle is locked. Click the vehicle search button, the horn sounds 3 times, and the turn signal lamp flashes 3 times.

3. Remote control unlocking function: press the remote control unlocking button, all doors will be unlocked, and all turn signal lamps will flash twice. Long press the unlocking function to remotely control the doors and windows to automatically descend to the bottom, and all turn signal lamps flash twice.

### **Door outside handle**

Pull the outside handle of the door outward and the door will open.

Insert the key into the door lock and rotate it in the direction shown to lock or unlock the door.



### Door inside handle

Pull out the inside handle of the door and the door will open.



### Attention



The key has the key brand number. After buying the vehicle, write down the key brand number. When the key is lost, you can inquire the manufacturer to obtain the corresponding key according to the key brand number.



The following conditions may affect the normal use of the remote control function:

①

Near the broadcast towers, high-voltage transformers, airports and other areas with strong signal interference or shielding;

②

There are other radio equipment such as mobile phones on the vehicle;

③

The key is wrapped in metal material;

④

Radio equipment is being used nearby.



When the signal is poor, pay attention to replacing the key battery.



Ensure that waste batteries are disposed of in an environmentally

friendly manner.



Avoid the following key damage behaviors:

①

Violently vibrate the key, including falling, falling from a height and other behaviors;

②

Avoid putting the key mold in high temperature environment, including putting it in direct sunlight for a long time;

③

Avoid putting it together with other hard objects to avoid damaging the key surface.

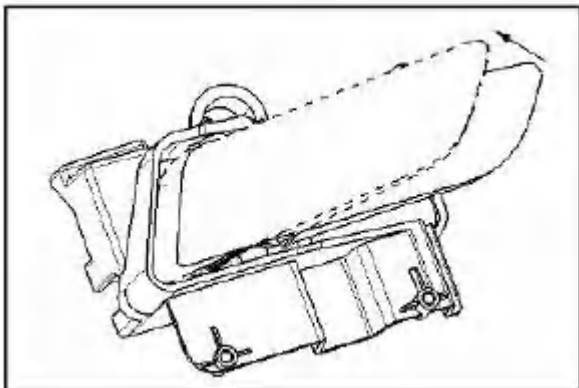

### Attention

- **Make sure all doors are locked when driving. After the door is locked, it can provide certain protection for passengers and drivers.**

- **When the vehicle stops, locking the door can also prevent thugs from invading.**

- **In any case, the door can be opened by pulling the inner handle, and escape the vehicle as soon as possible in case of accident.**

- **When leaving the vehicle, turn off the engine and lock all doors.**

### Driver's seat

Pull the adjusting lever in front of the seat upwards to adjust the position of the driver's seat back and forth. Lean on the seat and adjust the

seat to the appropriate position.



The cushion of the middle passenger seat can be folded. After the cushion is folded, the rear part can be used as a platform for placing small articles, which can be operated by the left handle.

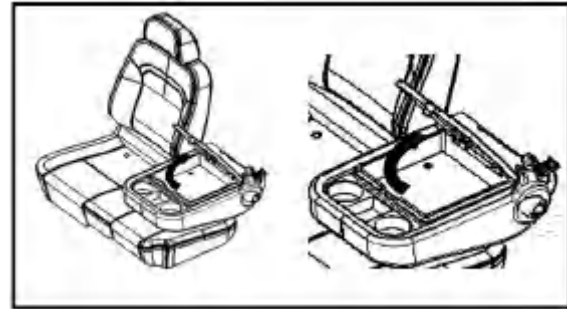

The passenger seat back can adjust the angle forward and backward. When in use, the human body is close to the backrest, and the adjusting handle on the door side can be adjusted to adjust the backrest angle forward and backward.

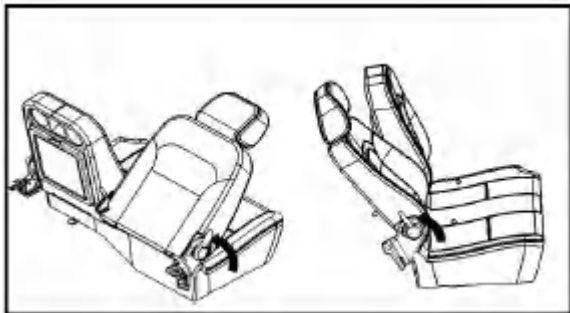

### Attention

- When the seat backrest is turned forward or backward, be careful to avoid interference and contact between the seat and the safety belt and the safety belt lock. This helps prevent damage to the safety belt mechanism.

- After manually adjusting the seat, apply body weight to push and pull the seat back and forth to ensure that the seat adjuster is locked.

- If the seat is shaking, it means that at least one adjuster is not engaged, which will increase the possibility of personal injury and the degree of accident injury.

- If it is found that your seat adjuster teeth cannot be locked, please send the vehicle to the service station for maintenance.

- When the vehicle is running, do not

**try to adjust the seat position and backrest, so as to avoid losing control of the vehicle.**

### **Folding seat (some models)**

Pull the adjusting lever in front of the seat upwards to adjust the position of the driver's seat back and forth. Lean on the seat and adjust the seat to the appropriate position. Remove the headrest of the driver, adjust the adjusting handle on the left side of the backrest of the driver, and the backrest can be turned over and leveled.

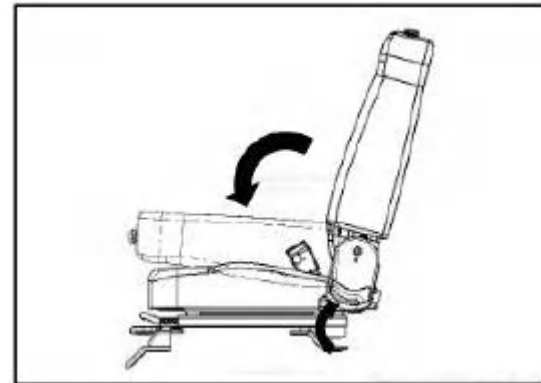

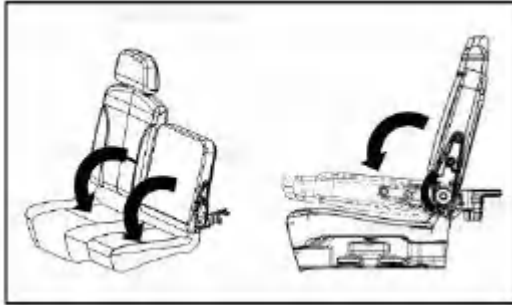

The cushions of the middle seat and the co-driver seat can be folded. After the cushions are folded, the sleeper cushions can be placed on the backrest for the driver to rest, and the adjustment mode can be operated by the left handle.

After the folding seat is laid flat, the sleeper cushion is placed on the backrest for lying.

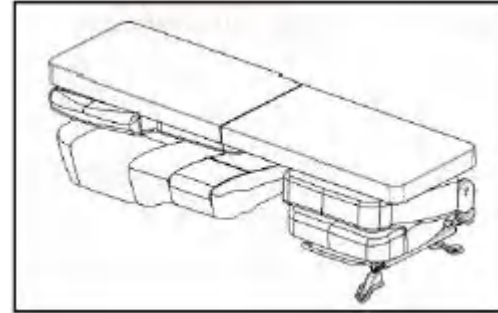

Airbag shock absorption seat is equipped with airbag shock absorption function, and button adjustment is not required.



## Seat belt

1 Adjust the seat to the ideal position, sit up straight, and keep the upper body close to the backrest. Hold the buckle tongue piece and perform the following steps:

① Pull the seat belt to a position that can bypass the lower abdomen.

② Hold the seat belt buckle tongue so that it is at right angles to the seat belt, slide along the seat belt and pull further forward.

③ Then slowly pull the buckle tongue across your body and insert it into the open end of the buckle until it makes a "snap" sound. If the safety belt cannot be pulled out due to the locking of the retractor before the buckle reaches the lock, let the safety belt retract slightly, and then pull the buckle at a slower speed than last time.

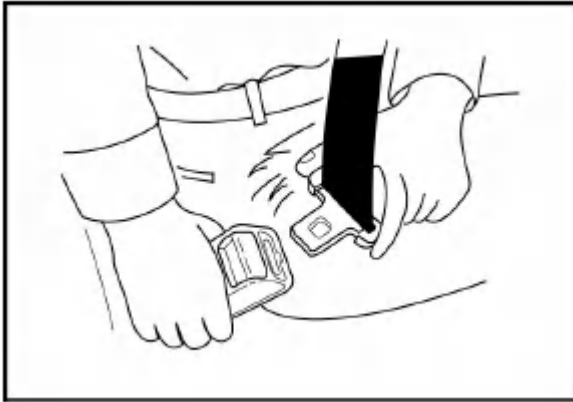

### **Warning**



**In order to reduce the risk of personal injury in the event of an accident, if the shoulder strap part is located or very close to the child's face or neck, the child should be**

---

**moved to a middle position away from the shoulder strap.**

---

2 In order to reduce the risk of users slipping off the safety belt during vehicle collisions, it is advisable to wrap the safety belt around the lower position of the buttocks as much as possible, and pull the safety belt through the buckle tongue piece towards the middle to the shoulder, so that the safety belt is tightly attached to the body.

Waist-shoulder safety belt can automatically lock the tension of safety belt during emergency brake or vehicle collision.



Usually, it automatically expands and contracts with the user.

3 Press the button on the buckle to release the safety belt. When the buckle is released, the safety belt will retract back to the retracted state. To prevent touching people or nearby objects during contraction, hold the tongue piece of the buckle and let the safety belt shrink. To prevent damage to safety belts and interior trim, make

sure that the safety belts are fully secured and that the buckle is not an obstacle before closing the door.



## Inspection and maintenance of safety belts

1. Check your seat belt regularly. Whether the buckle, buckle tongue piece, safety belt retractor, support, etc. are damaged, so as not to reduce the

safety effect.

2. Do not place objects with sharp edges that will cause damage near the seat belt.
3. If the seat belt is strained, weakened, cracked or subjected to collision load, it shall be replaced.
4. Check whether the support fixing bolts are firmly tightened on the floor.
5. Any parts found to have problems shall be replaced.
6. Keep the seat belt clean and dry.
7. Seat belts can only be cleaned with weakly alkaline soap and water.

8. Do not bleach or dye the seat belt, otherwise the strength of the seat belt will be weakened.

9. Seat belts shall be prevented from being contaminated by varnish or engine oil, chemicals, especially battery electrolyte.

10. Users shall not modify or attach anything to the seat belt, which will affect the function of the seat belt.



## Warning

---



**It is important to know how to use safety belts correctly. At the same time, whenever the vehicle is running, make sure that all**

---

---

**passengers use the safety belts that have been properly adjusted.**

---

## **Mirror**

### **Inside rearview mirror**

When adjusting, the rearview mirror can be swung left, right, up, and down.

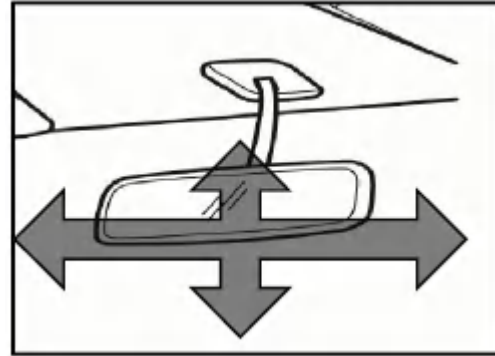

### **Front under-view mirror, blind mirror**

The front under-view mirror is optional according to different models. When adjusting, the front under-view mirror can be swung left, right, up, and down.

The blind mirror is optional according to different models. When adjusting, the blind

mirror can be swung left, right, up, and down.

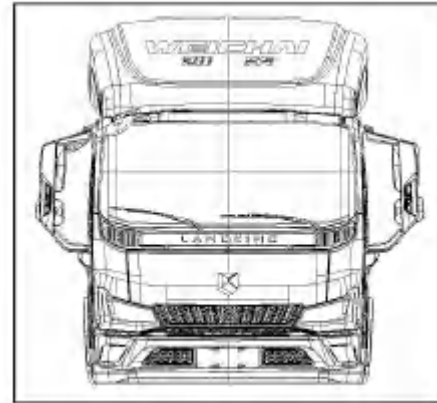
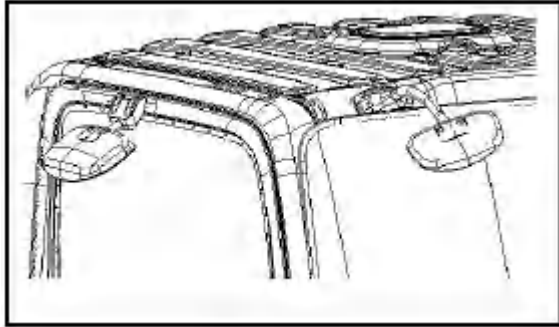

## Outside rearview mirror

Adjust the left and right exterior rearview mirrors, so that you can not only see the left and right sides of the vehicle, but also see the surrounding environment within a certain range on the left and right sides of the vehicle. This helps to judge the relationship between objects behind you from the mirror.



**Danger**



**Do not adjust the outside rearview mirror while the vehicle is running.**

## List of daily inspection of drivers

### **Driver inspection (routine inspection)**

In order to ensure safe and reliable driving, the following items should be checked (please refer to the relevant contents in the chapter "Repair and maintenance" for correct inspection steps).

### **External**

- 1 Check tire pressure and damage.
- 2 Check whether the wheel nut is loose.

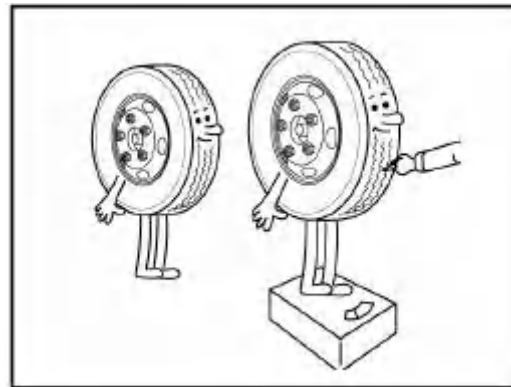
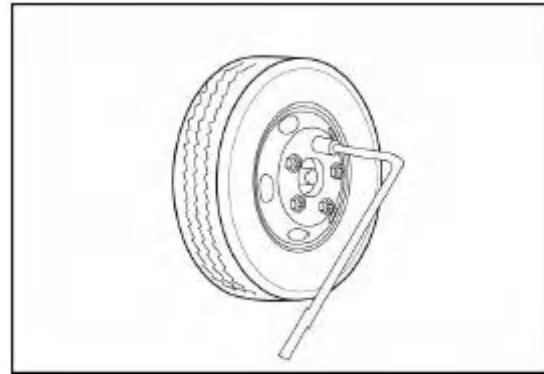

3 Check whether the headlamp is normal and effective.

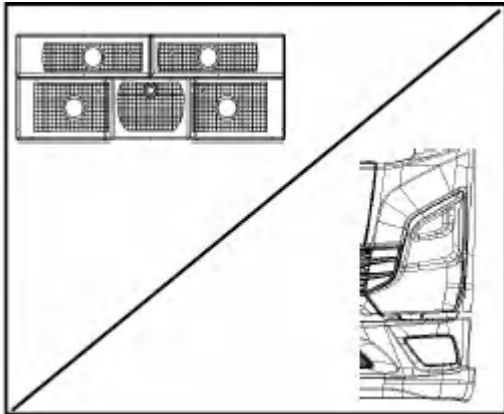

4 Check whether the chassis leaf spring is damaged.

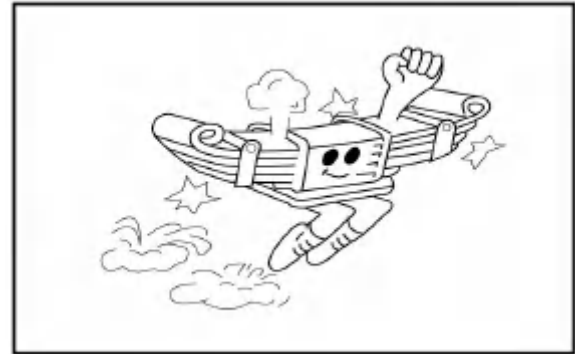

5 Check whether there is leakage of engine oil, water, fuel, brake fluid, power steering fluid, urea, etc.

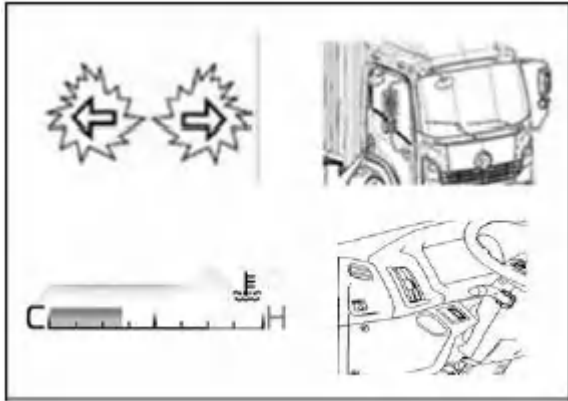

6 Check whether the engine coolant level and auxiliary radiator cover are loose.

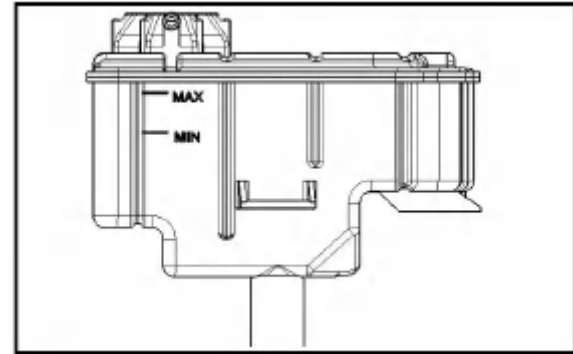

### In the cab

1. Check the free stroke and stability of the steering wheel. If the vehicle is equipped with a power steering gear, check the free stroke of the steering wheel with the engine running: the total stroke from center to left and to right is (0–25) mm.

2. Check whether the horn, windshield wiper and turn signal lamp can work normally.

3. Check whether each instrument and indicator can work normally.



4. Check whether the oil level in the fuel tank indicated by the fuel gauge is normal.

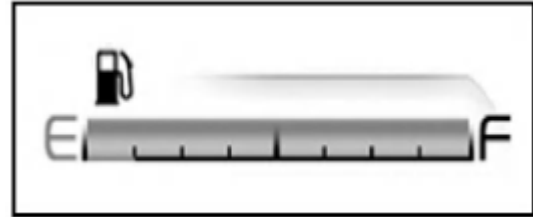

5. Check whether the urea level in the urea tank indicated by the urea meter is normal.

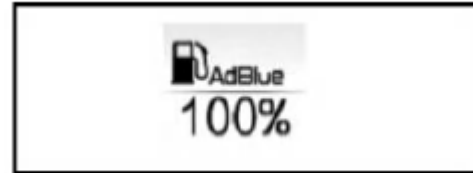

6. Check whether the setting angle of each rearview mirror is appropriate.

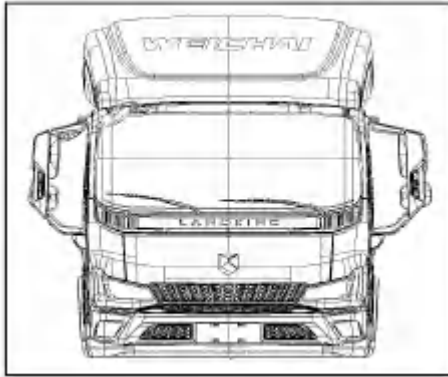

7. Check whether the level of clutch liquid in the oil storage cup is normal. The liquid level should be between Min and Max.



8. Check whether the washer liquid level in the windshield washer is normal.

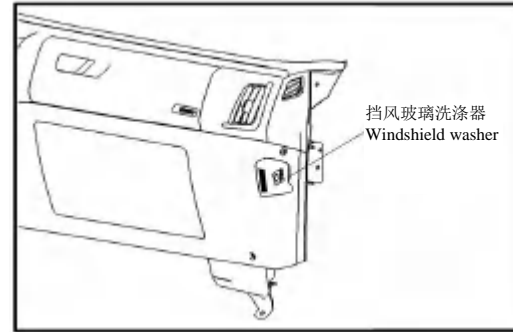

9. Check whether the door locking mechanism can work normally.

10. Check the free stroke and function of brake and clutch pedal assembly.

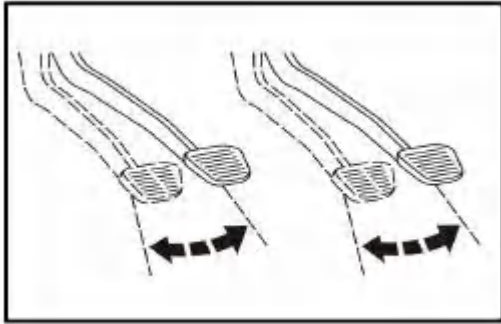

### Inside the engine compartment

1. Check the oil level of the engine.

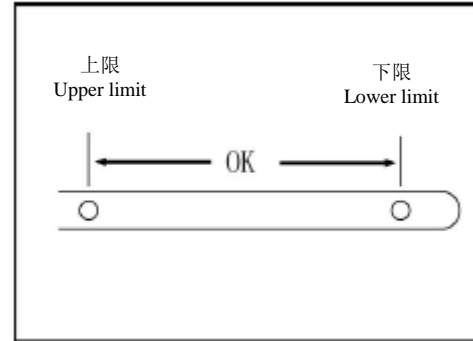

2. Check the tension degree of fan belt.

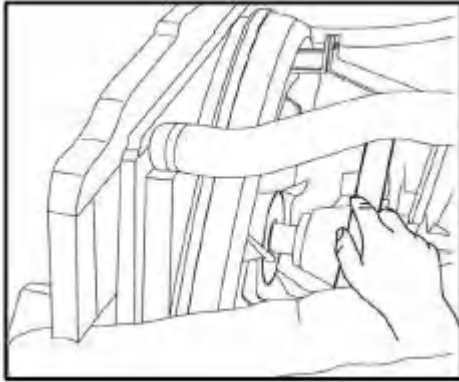

3. When the engine is running, check whether the charging fault alarm lamp, oil pressure low alarm lamp and OBD diagnostic lamp are off and being off.

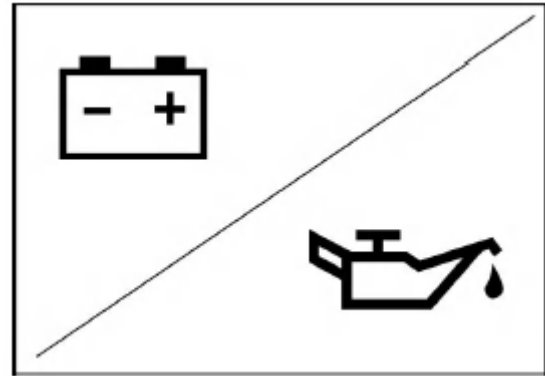

4. Check whether the engine has abnormal noise and the color of exhaust gas.

## Driving operation

### Preparation before engine starting

Proper maintenance and driving can not only prolong the life of vehicles, but also improve the economy of using fuel and oil.

#### 1. Check the coolant level:

If there is not enough coolant, open the lid to add coolant. Do not add a large amount of coolant when the engine is in a hot state. If there is no coolant under exceptional circumstances, it is allowed to slowly add distilled water with a moderate temperature, and add coolant from the filling port until it overflows. Start the engine, continue to fill up the coolant until the liquid

level is stable when the engine is running (1,000 r/min), and finally cover the coolant filler cap.

#### 2. Check the fuel level:

Turn on the power switch and check the fuel level from the fuel gauge or the fuel tank.

#### 3. Check the oil level:

The oil level should be between the upper and lower scale lines of the dipstick. If necessary, add oil from the oil filler.

4. Check the connection of various parts and lines: check whether the connection of various accessories of the engine is reliable and eliminate abnormal phenomena.

Check whether the circuit connection of the starting system is normal and whether the battery is fully charged. Then open the fuel tank valve, loosen the bleed screw on the fuel coarse filter, and use the hand pump on the fuel coarse filter to drain the air from the fuel system.

5. Check the urea level in the DEF tank

Generally, urea consumption accounts for 3%–5% (volume ratio) of fuel consumption. The liquid level of urea solution should be checked according to the usage, and the liquid level should be kept between 30%–80%. If the urea solution is insufficient, it should be added in time; nor can it be added excessively, resulting in urea overflow.



6. Check whether the parking brake handle is pulled up.

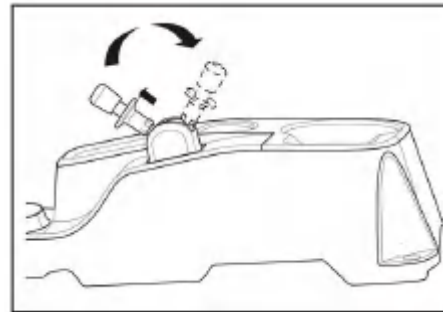

7. Hang the shift lever in neutral position.

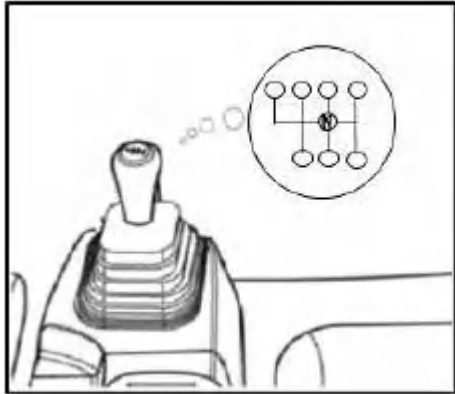

## Engine starting

1. When starting conditions are met, turn the electric key to start the engine. When starting is difficult, the continuous starting time should not exceed 10s. After the key returns, wait for 1 min before repeating the above starting process. When the continuous starting time exceeds 10s,

ECU will report an error. But if it cannot be started for three consecutive times, the start should be stopped and the cause should be identified and the fault eliminated before starting. After starting the engine, pay attention to the readings of each instrument, and the oil pressure gauge should show the pressure immediately. Be careful not to let the cold engine run at high speed. First, idle for a period of time, but the idle time should not be too long (30s). Check the oil pressure and water temperature.

2. When starting the engine at low temperature, the auxiliary starting device should be used, and the electronic heating flange shall be operated through relay, so as to realize smooth starting at -30 °C.

## Engine shutdown

1. Before the diesel engine stops, the load should be gradually unloaded, run at medium and low

speed for several minutes, and then turn off the power supply and stop after the cooling water temperature drops below 70 °C.

2. In case of emergency, when the diesel engine needs to stop immediately, it can be stopped by turning off the power supply directly.

### **Engine exhaust warning**

Avoid inhaling the exhaust gas from the engine, because the exhaust gas contains carbon monoxide, which is a colorless and tasteless gas. If inhaled into the human body, people will lose consciousness and even die. Make sure the exhaust system has broken holes or loose connections. Please check the exhaust system from time to time. If you hit something or find abnormal exhaust sound, check the exhaust system immediately.

Unless the vehicle must enter or leave the garage, the engine must not be operated in the garage or in a closed place. Because the exhaust can't escape in these places, it will cause a very dangerous situation.

Do not stay in the parked vehicle for a long time while the engine is running. If it is unavoidable, park the vehicle in an open place and adjust the air conditioning system to allow outside air to enter the vehicle.

### **Exhaust gas treatment device**

Exhaust gas treatment device is a kind of exhaust pollution control device installed in the exhaust system, and its function is to purify the exhaust gas.



## Warning

---

- When the engine is running, because the exhaust pipe temperature is very high, people and flammable materials should be kept away from the exhaust pipe.
  - Do not idle or idle on the grass and in the environment where leaves, paper or rags are easy to cause combustion.
- 



### Attention

● If a large amount of unburned gas

flows into the exhaust gas treatment device, it will cause the exhaust gas treatment device to overheat and fire. In order to prevent this and other hazards, the following precautions must be observed:

- Do not drive the vehicle at extremely low fuel level, because lack of fuel will cause the engine to miss fire and increase the overload of the exhaust gas treatment device.
- Avoid idling the engine for more than 20 minutes.
- It is strictly forbidden to start the engine by pushing or towing the vehicle.

- **Do not turn off the ignition switch while the vehicle is running.**

- **If the engine is difficult to start or often stalls, please check at the service station as soon as possible.**

- **In order to ensure the proper operation of the exhaust catalytic converter and the entire exhaust control system, your vehicle must undergo regular maintenance and inspection as specified in the maintenance schedule.**

After-treatment system

**Composition of after-treatment system**

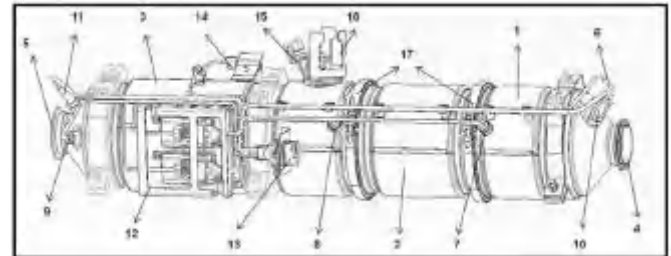

The after-treatment system is used to reduce NOx and particulate matter emissions and consists of 17 parts:

1. DOC components.
2. DPF components.
3. SCR component.
4. Air inlet.
5. Exhaust port.
6. Front DOC temperature sensor.
7. Rear DOC temperature sensor.
8. Rear DPF temperature sensor.
9. Rear SCR temperature sensor.
10. Front nitrogen oxide sensor.
11. Rear nitrogen oxide sensor.
12. Protective rack of nitrogen oxide sensor.
13. After-treatment transition harness.
14. Pressure sensor.
15. Urea nozzle.
16. Urea nozzle protective rack.

17. DPF removal clamp.

### **Function of each part of after-treatment system**

1. The after-treatment inlet and outlet are automobile after-treatment exhaust pipes, which are connected with adjacent parts.
2. After-treatment pressure sensor detects the pressure difference between two ends of DPF of diesel after-treatment catalyst.
3. The PM oxidation catalyst is used to treat soot and ash emitted by engine.
4. The diesel oxidation catalyst can remove HC and CO in tail gas and SOF in PM by oxidation, and can also oxidize NO to NO<sub>2</sub>, which prepares

for passive regeneration in PM oxidation catalystr.

5. Soot is composed of particles burned by part of fuel when the engine is working normally (black smoke).

6. Dust is composed of particles burned by some engine oil during normal operation of the engine.



### Attention

- **If diesel with very low sulfur content is not used, the engine may not follow the emission rules, and the after-treatment diesel particle oxidation catalytic converter or diesel oxidation catalytic converter may be damaged.**

### After-treatment feeding unit

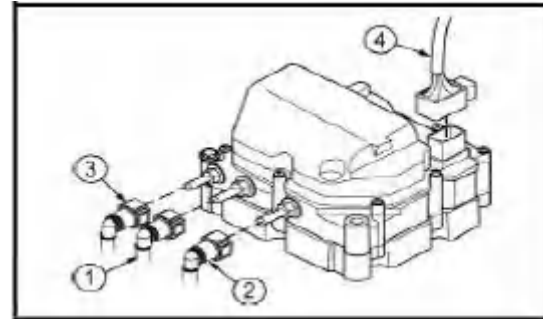

1 Return to the pipeline of the urea tank.

2 Pipeline flowing into after-treatment feeding unit.

3. Pipeline flowing into after-treatment injection unit.

4 Power line.

Reinstall after disassembly, and do not install the pipeline sequence of ① ② ③ incorrectly.

The after-treatment feeding unit contains a 10 micron filter screen, which needs to be replaced regularly. When replacing the filter screen, the sealing gasket needs to be replaced together.

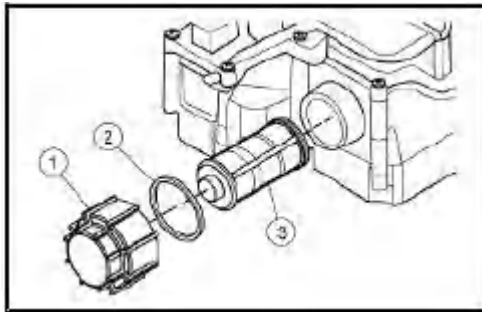

1. Protective cover.

2. Gasket.

3. Filter screen.



### Attention



**The after-treatment feeding unit should not be immersed in any liquid.**



**Do not clean with any detergent.**



**Wipe with a clean wet towel.**



**If there are cracks on the surface, the power connector is damaged,**

and the quick-plug connector is damaged, it needs to be replaced as a whole.

Precautions for after-treatment system



### Attention

- **Fuel:** must use the fuel meeting national VI and above requirements (GB19147-2013 sulfur content is less than 10 ppm). If the fuel does not meet the requirements, it will lead to frequent regeneration of diesel particulate trap, even fault of regeneration, blockage, increase of fuel consumption, deterioration of

engine performance and even damage to engine.

- **Oil:** CK-4 quality grade oil must be used, and its low ash characteristic is the premise to ensure the normal operation of engine and after-treatment system and meet the emission requirements, otherwise the life of diesel particulate trap will be reduced.

- **Warranty:** the fault of engine and after-treatment system caused by the use of unqualified fuel or engine oil is not covered by Weichai warranty.

DPF performs diesel particulate filter

## **regeneration in situ**

### **Confirmation before DPF regeneration:**

1. Keep away from other vehicles, people and inflammable and explosive materials when regenerating services to avoid unnecessary impacts;

2. The vehicle is completely stationary and the handbrake is pulled up;

3. The vehicle is in neutral state;

4. The clutch is not engaged;

5. The brake has not been pressed;

6. The throttle has not been pressed;

7. The vehicle is in-situ idling condition;

8. Check the cooling water pipe of urea nozzle to ensure that the pipe is not bent and the circulating water flow is smooth;

9. Check whether there is smoke and air leakage in the pipeline, and whether the thermal insulation package is complete and effective. If the thermal insulation package is damaged or missing or there is obvious air leakage, please contact the local service station in time;

10. Check whether the sensor harness such as after-treatment is more than 5 cm away from the surface of exhaust system components and reliably fixed to avoid baking of the wiring during regeneration;

11. Check whether there are flammable materials scattered near DPF box and supercharger to avoid open flame during regeneration;

12. During the regeneration process, the internal temperature reaches 600 °C, and the external surface temperature is also high, so it is necessary to carefully check the insulation package, harness layout and flammable items;

13. The driver of the current driving cycle needs to press the clutch all the way down before releasing it for the first time when starting the car with electricity, and then press the regeneration switch to trigger it in order to be effective.

### **DPF regeneration process**

1. After the DPF lamp is always on, choose a suitable place for DPF regeneration as soon as possible, and confirm the preparation according

to the above before DPF regeneration;

2. Full warm-up: It is recommended that the instrument show that the water temperature is above 50 °C before regeneration, so it is recommended to regenerate immediately after driving. At this time, the water temperature is high, the hot vehicle is sufficient, the regeneration duration is short, and the fuel economy is good;

3. After meeting the above conditions, press the active service regeneration request button (self-reset switch), press it for about 1s–2s and then release it, and the long press time cannot exceed 5s;

4. After the engine water temperature rises to a certain extent, the idle speed of the engine automatically starts to increase, and then the engine automatically runs. In principle, after pressing the active service regeneration switch,

the driver should not interfere with the engine and the vehicle. Forced intervention will easily cause faults such as urea nozzle burning. In case of accidents, please follow the treatment under special circumstances;

5. In the whole process of regeneration, the idle speed of the engine is increased to about 1000 r/min –1400 r/min, and then increased to about 1700 r/min–2000 r/min after a stable period of time. After stable operation for about 25 minutes, the engine returns to idle speed again, and the complete regeneration process is completed, and the DPF lamp goes out. If it is necessary to shut down the engine at this time, it is recommended to idle the engine for another 5 minutes after the regeneration process to exhaust the superheated gas in the after-treatment tank, and then shut down the engine. In principle, do not turn off the battery power directly after turning off the engine. If you need to turn off the battery power, you should stop normally for at least 5 minutes before turning it off.



### Attention

● **Be careful to observe the air leakage and smoke in the exhaust pipe during regeneration. If obvious air leakage and smoke are found, please follow the treatment under special circumstances.**

### Parking (some models)

When leaving an unattended vehicle:

1. Pull up the parking brake manual valve.

2. When parking on the uphill, put the shift control lever in the first gear position; When parked downhill, put the shift lever in reverse position.

3. Turn the ignition switch key to the "LOCK" position.

4. Take the key.

5. Close all windows and lock all doors.

6. Check and make sure the lights are off.

7. If the vehicle is parked on a slope and unattended, the wheel stops must be padded.

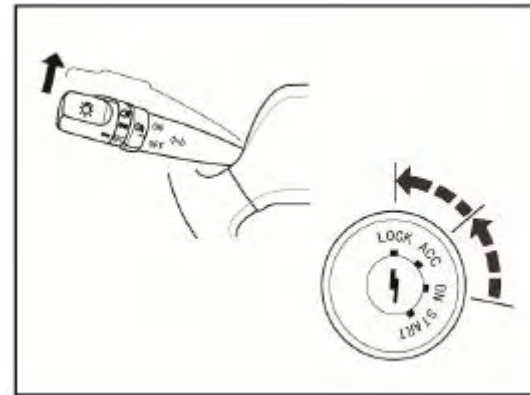
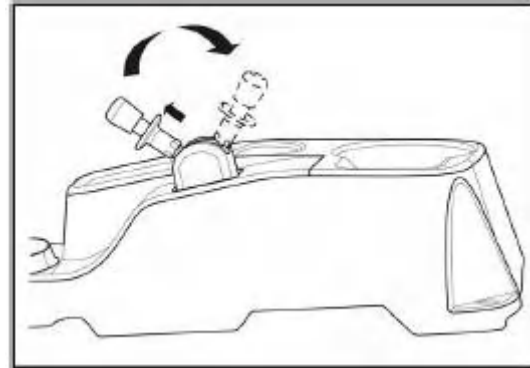



## Danger

- Do not leave unattended children alone in the vehicle. Children may operate the control devices on the vehicle to cause accidents.

- Do not drive through or park your vehicle near or idle above flammable materials such as hay or dried leaves, which may come into contact with the high-temperature exhaust system to cause combustion.

- Do not leave an unattended vehicle while the engine is running. If you are absent, the engine will cause

- damage to the vehicle and internal parts when the temperature alarm light is on or the coolant temperature gauge warns of overheating.

- If you stop halfway, please choose a suitable and safe parking place.

## Driving precautions

1. Avoid overspeed running of the engine.

When driving downhill, pay attention to avoid overspeed running of the engine especially. Especially when changing into low gear, the

engine is most likely to run at overspeed.

2. If abnormal sound and odor are found in driving, stop for inspection and find out the cause of fault.

3. If you find that the indicator or instrument indication is abnormal during driving, stop for inspection immediately, and find out the cause of fault.

4. Avoid sudden acceleration and emergency braking as much as possible.

5. Do not put your feet on the clutch pedal when driving, otherwise, the clutch may be in a semi-separated state, resulting in premature wear of the clutch friction lining.

6. Stop the vehicle completely before the shift

lever is shifted from the forward gear to the reverse gear or from the reverse gear to the forward gear.

7. When climbing, in order to avoid overload of the engine, the shift lever should be switched to the low gear in time before the engine starts to load and decelerate.

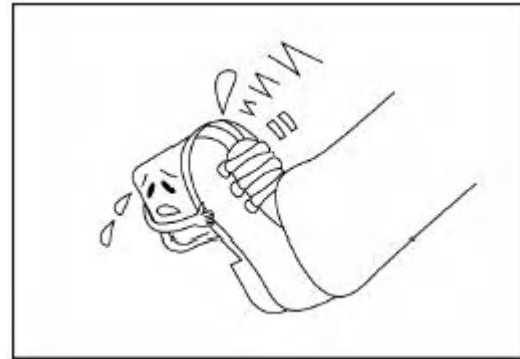

8. When going downhill, shift into low gear to achieve the deceleration of engine braking.

9. When crossing shallow rivers or deep pits during driving, take care not to let water into the gas pipeline, causing serious damage to the engine. After passing through the water, check whether there is water in the gear oil of the rear axle and transmission. If mixed with water, drain it and then re-filled with the specified gear oil.

10. After driving in heavy rain or through shallow rivers, be very careful when driving, because the brake will temporarily reduce the braking force due to dampness.

11. Never stop the engine while driving. Otherwise, the braking effect will be reduced due to the stop action of the brake booster. If you turn the start switch to the "LOCK" position while driving, it will cause great danger. At this time, the steering wheel cannot control the vehicle because it is locked.

## Economical driving

1. Unnecessary high-speed driving and low-speed driving in high gear will increase fuel consumption and reduce the service life of vehicles.

2. After acceleration, put the shift lever into the high position and slowly release the clutch pedal.

3. After shifting the shift control lever into direct gear or overdrive gear, maintain a certain speed as far as possible.

4. When driving, keep the coolant temperature within the normal range. If the water temperature suddenly rises, stop and check in time to avoid serious damage to the engine.

5. Underinflated tires will reduce fuel economy

and tire service life.

Winter vehicle management and maintenance

### Use of antifreeze (ethylene glycol)

The freezing temperature of engine cooling water will change with the amount of antifreeze in it.

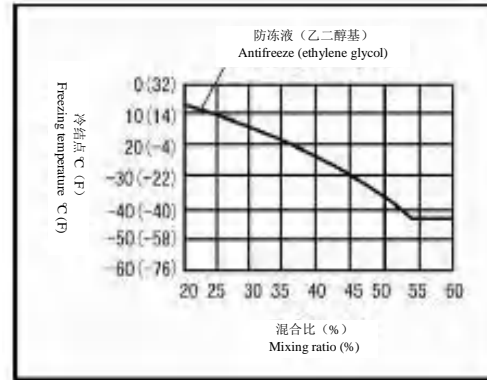

1. The appropriate mixing ratio of antifreeze can be determined according to the curve shown in the above figure. The user should confirm that the selected antifreeze meets the minimum ambient temperature requirements of the use area to prevent the liquid from freezing.

2. To replace coolants of different brands or models, it is necessary to flush the interior of the cooling system including radiators.

3. When there is scale in the cooling system, before adding new antifreeze, use the water tank cleaning agent to remove scale, otherwise the additive in antifreeze reacts with scale to produce flocs.

4. It is forbidden to mix different types of antifreeze.

5. The antifreeze replacement cycle is 2 years. If the antifreeze is found to be discolored and muddy, the antifreeze shall be replaced.

6. The damaged rubber hose shall be replaced, because when using antifreeze, even if the cracks in the rubber hose are small, the engine coolant will leak outward.

## Engine oil

As the temperature decreases, the engine oil will thicken, so choose engine oil with viscosity suitable for the outside temperature (refer to the relevant contents in the "Lubrication" section of the "Repair and Maintenance" chapter for the selection of engine oil grades).

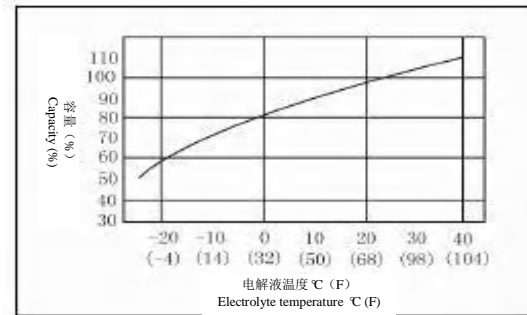

## Battery

The capacity of the battery will decrease with the decrease of the outside temperature. The

specific gravity of electrolyte also decreases with the increase of discharge rate.

Therefore, necessary measures should be taken to prevent the battery from freezing.

### Driving on ice and snow

1. It is recommended to use wheel anti-skid chains or snow tires.

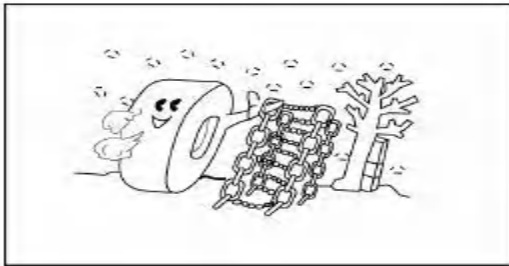

6.50R16\7.00R16\7.50R16\8.25R16\8.25R20\215/75R17.5\205/75R16\205/75R17.5\235/75

R17.5\265/70R19.5 tire available specifications  
2206/4206CAM\2219/42197CAM\2219/42197CAM\2233/4233CAM\2239/4239CAM snow chains.

2. Avoid high-speed driving, sharp acceleration, emergency braking, and sharp turns.

3. Use a low gear to obtain engine braking effect, and use the foot brake pedal carefully.

4. Keep a sufficient distance from the vehicles in front of you when driving.

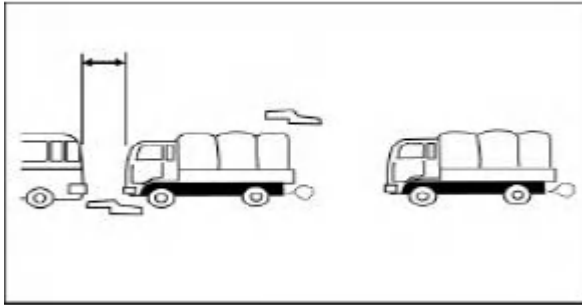

In an emergency

## **Engine overheat**

If the engine overheats:

1. The coolant temperature gauge scale will be displayed in the bar alarm area of it.

2. The "bang" sound of the engine becomes louder.

3. The output power of the engine decreases.

4. When steam or boiling water is sprayed from the water tank cap, it is forbidden to tip over the cab immediately, and it can not be tipped over to provide good ventilation until no abnormal noise or steam is heard.

5. Keep the engine running at a slightly higher speed than idle speed (about 1200 r/min) for 5 min–10 min. If there is coolant leakage, stop the engine immediately.

6. Stop the engine, and let the engine and radiator cool down.

7. Carefully remove the auxiliary radiator cover.

8. When the engine cools, check the liquid level of the auxiliary radiator. If necessary, fill the coolant to ensure that the coolant level is between Max and Min lines.



### **Danger**

● **To avoid burns, please do not remove the cap of the auxiliary radiator while the engine and radiator are still hot.**

● **If the cap of the auxiliary radiator is removed too quickly, hot liquid and steam will spray out and burn people under the action of pressure.**

● **The ethylene glycol coolant in the engine is combustible under certain conditions. When filling this coolant, do not splash it on the exhaust system or hot parts of the engine.**

### **Emergency stop**

1. If it is necessary to park vehicles on the road for some reason, keep the vehicles as close to the roadside as possible, and never park them on the carriageway.
2. Make the parking brake turn to the braking state reliably, and use the danger warning flash during the day and night.
3. Place danger warning signs behind the vehicle.

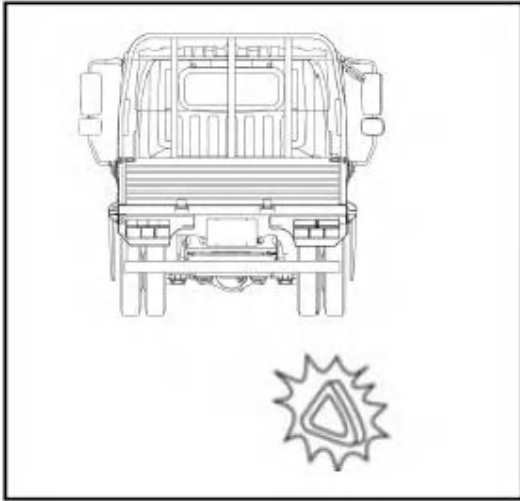

### Emergency start

Do not start the engine by the towing of another vehicle. Because when the engine starts, the vehicle may impact forward, causing a collision with the towing vehicle.

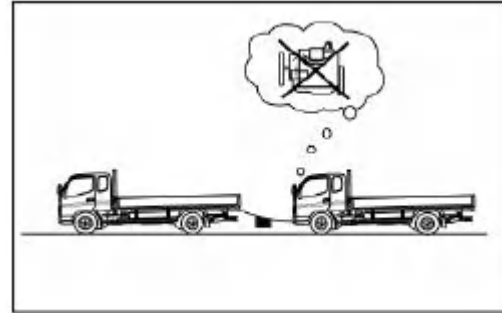

When the vehicle is started with the battery is exhausted, use an auxiliary battery with the same rated voltage and capacity.

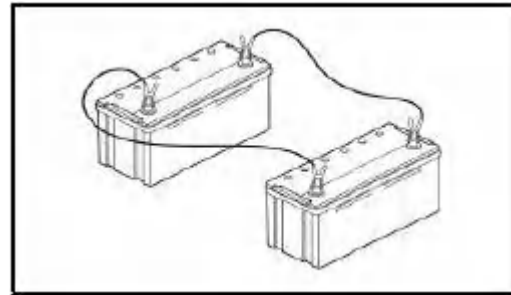

## Traction of air-cut brake vehicle

### **Front-end traction**

Traction method with all wheels on the ground or front wheels not on the ground.

When the driving operation can be carried out normally, your vehicle shall pull all the wheels for traction. At this time, power steering will have no power. If the air pressure of the braking system is too low, the brakes of the vehicle will fail. Between the tractor and the vehicle losing driving efficiency, either the tractor air source is connected, or the spring brake is released to release the brake, and the hard traction is used to connect the traction.

If the air pressure is reduced, the front and

rear spring brakes can be loosened by hand. Please loosen the brakes by hand, and the specific methods are as follows:

1. Remove lock bolts and nuts on the brake axle side.
2. Remove the rubber cap from the rear axle.
3. Place the lock double head screw with nut and flat washer into the axle (rubber cap removed), and turn it clockwise 1/4 times.

Turn the nut of the stud several times with a wrench to reduce the resistance when loosening the brake valve. When the screw exceeds 70 mm, the spring brake will be able to release the brake.

1. Turn the nut at the back of the spring energy storage chamber clockwise.

2. When the screw is extended to about 70 mm, loosen the spring brake by hand.

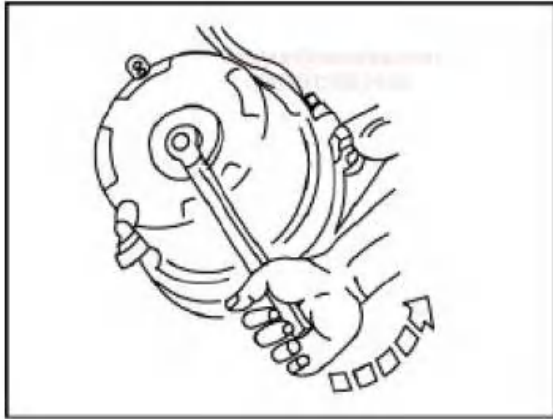

3. When releasing the spring brake, block the wheels, and then hang the towing cable (safety chain or steel cable) on the hook of the tractor and the damaged vehicle.

In the event of a transmission fault, detach the drive shaft from the rear axle flange, and fasten its end to the frame.

Then, hang the towing cable (safety chain or cable) on the hook of the tractor and the non-running vehicle, and pull it at a speed of 40 km/h or less, which the traction distance is less than 80 km.



### **Danger**

- **The traction device of the vehicle is only used under normal road surfaces and rated load.**
- **If the vehicle is equipped with two towing hooks, double hooks must be used for traction, and the force on the two traction hooks shall be**

**uniform.**



**When the vehicle has special circumstances such as sunken wheels or high-raised obstacles, it shall be unloaded before traction.**



**If it is still difficult to tow or inconvenient to unload after unloading, please ask a special traction service unit to take charge of traction, and do not drag it by force, so as not to cause wheel damage.**

## Rear-end traction

When the rear wheels are off the ground, fix the steering wheels to keep them in the front position.

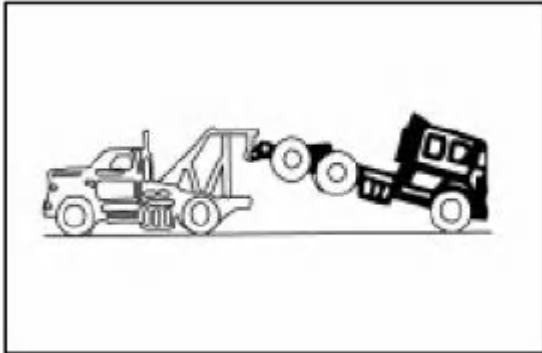

## Cable connection steps

The jumper cable can be connected to the battery of another vehicle to start the engine of the faulty vehicle.

1. Use vehicles equipped with batteries with the same rated voltage of 12 V/24 V.
2. Connect the cables in the following order:
  - ① Positive terminal of the discharged battery.
  - ② Positive terminal of the auxiliary battery.
  - ③ Negative terminal of the auxiliary battery.
  - ④ Chassis grounding wire equipped with the battery discharging all electricity, which should leave the storage battery as far as possible.

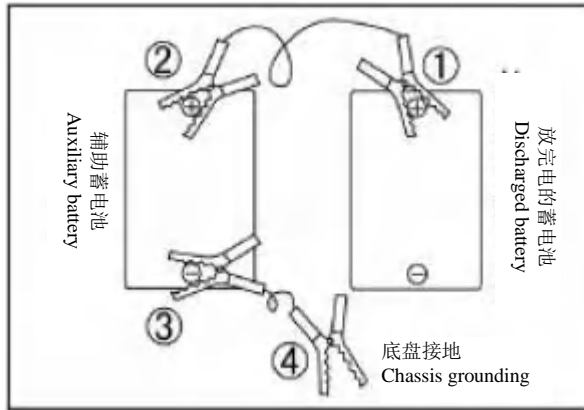

3. After connecting the jumper cable, start the engine of the vehicle equipped with an auxiliary battery.

4. Increase the engine speed of a vehicle equipped with an auxiliary battery, and then start the engine of the vehicle whose battery has been discharged.

5. After starting the engine, detach the jumper cables in the reverse order of connection.



## Warning



**Never connect the cable between the positive and negative terminals.**



**Do not detach the cable from the terminal while the engine is running, otherwise, it will cause a**

---

**fault in the circuit system.**



**The battery will produce flammable and explosive hydrogen and oxygen gas. If the jumper lead is not connected correctly, it will produce an electric spark, which will cause the explosion of the battery.**



**The battery contains sulfuric acid, which can cause serious burns.**



**If sulfuric acid is splashed on eyes, skin, or clothes, rinse with plenty of water. If sulfuric acid splashes into eyes, please seek medical advice immediately.**

---

**Exhaust and water discharge of fuel system**

If the fuel in the fuel tank is completely used up, the fuel system is likely to have sucked in air. At this point, the fuel will be blocked and cannot flow into the engine smoothly. In order to prevent it, it is necessary to exhaust the fuel system.

1. Unscrew the exhaust bolt counterclockwise.
2. Operate the manual pump handle back and forth until fuel overflows at the exhaust bolt.
3. Carefully and quickly tighten the exhaust bolts clockwise.

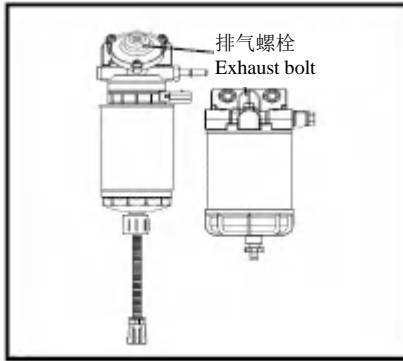

4. After the exhaust of the fuel system, start the engine.

5. If the engine does not start within 10s, repeat steps 1 through 4.

6. Drain water regularly: carefully loosen the drain cock counterclockwise.

7. Continue to drain the water for about 10s.

8. After draining water, tighten the drain cock clockwise, and then inject fuel according to steps 1 to 3.

9. After starting the engine, check whether the fuel leaks outward through the drain cock. and whether the fuel filter indicator is off.



---

### Warning



**If it is necessary to drain from time to time, please ask the Special Repair Station of our Company to remove the water in the fuel tank.**

---

## Replacement of air-leaking tires

:

In order to avoid personal injury, operate it according to the manual of lifting device and loading equipment:

1. When jacking up the vehicle, do not drill under the vehicle.
2. Keep the spare tire (or inner tire) and all lifting devices at all times.
3. Do not start or run the engine when the vehicle is on the lifting jack.
4. Be sure to place the lifting jack on a solid plane.

## Preparation

1. Park the vehicle on flat ground, and pull up the parking brake handle.
2. Put the shift lever into the "R" (reverse) position.
3. Turn on the danger warning flash.
4. Block the wheels on the diagonal side of the jacking position with stops.
5. Loosen the wheel nuts, but do not remove them.
6. Place the lifting jack under the jacking fulcrum specified below.

## Front wheels

Put the lifting jack under the I beam.

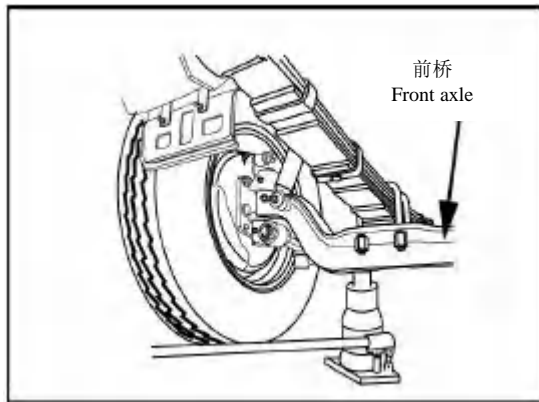

## Rear wheels

Place the lifting jack at the rear axle shown.

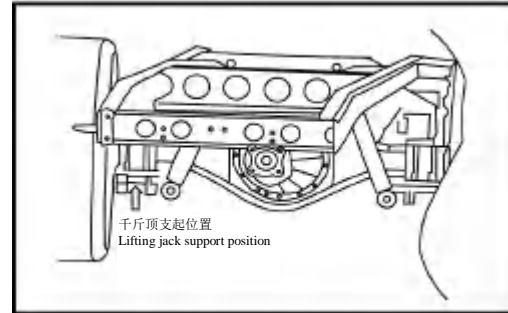

## Operation instructions for lifting jack

### Jacking up

If the jacking fulcrum of the vehicle is higher than the lifting jack head, turn the lifting jack head counterclockwise to make it stretch. As shown in the figure, insert the lifting jack handle and pull it up and down.

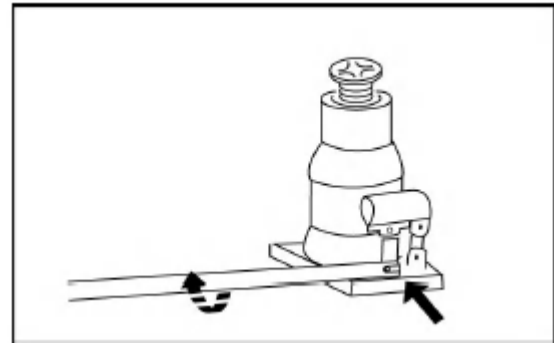
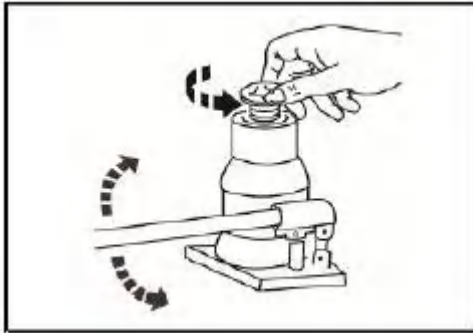

### Putting down

With the lifting jack handle in the state shown in the figure, slowly loosen the oil return hole screw counterclockwise.



## Warning



**Do not place the lifting jack outside the specified fulcrum.**

## Replacement of wheels

1. Jack up the vehicle until the tires requiring wheel replacement have just left the ground, unscrew the wheel nuts, remove the wheels, and then install the spare wheels.

2. Install the wheel nuts, then screw each wheel nut to the semi-locked position with the wheel wrench, and loosen the oil return hole screw of the lifting jack counterclockwise to lower the vehicle to the ground.

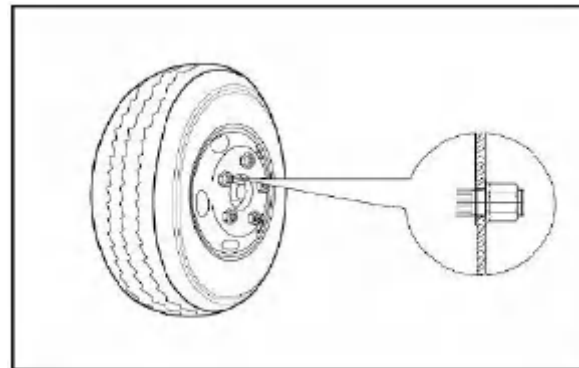

3. Tighten all wheel nuts with the wheel wrench in the sequence shown, and the locking torques are shown in the section "Maintenance guide" in the chapter "Repair and Maintenance".

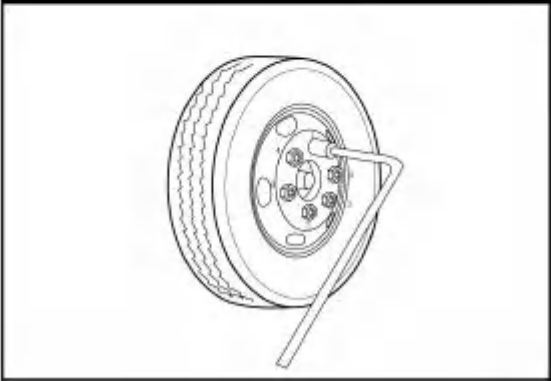
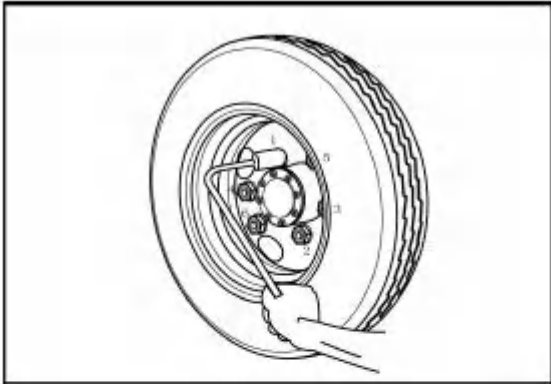

## Security

### **Electronic Stability Control Program (ASR)**

Vehicles equipped with ASR system have the functions of ABS (Anti-lock Braking System) and ASR (Anti-skid Wheel System). ASR (Wheel Anti-skid System) works together with ABS as a supplement to ABS system.

ASR system optimizes the driving force to prevent wheel skidding by acting on the braking system and engine. At the same time, the steering stability during acceleration is improved.

### **Active**

When the vehicle starts, the system automatically activates.



### **Danger**

- **ASR system can improve the safety of driving, but dangerous driving should not be conducted based on it.**
- **Drivers should still drive vehicles carefully according to road conditions and traffic conditions.**
- **To ensure the normal operation of the system, tires and rims, brake components, and electrical components and assemblies of the**

**same specifications approved by our company must be used, and maintenance must be carried out at our Special Repair Station.**



**After the collision of the vehicle, please go to the Special Repair Station of our company to check the system.**

### Reversing radar (some models)

The reversing radar system is used to assist drivers in reversing safely. It consists of a controller and a radar probe.

The probe is mounted on the rear guard, and the controller is mounted on the pipe beam under the cab. When reversing, the radar probe detects

the obstacle information within 1.8 meters behind the vehicle and transmits it to the radar controller, which gives a buzzer alarm prompt, and the driver can hear the buzzer alarm sound, thus assisting the driver to park safely and easily and avoid collision.



### **Danger**

- **If equipped with the reversing radar, please read its instruction manual carefully before using it.**
- **If the corresponding instructions are not followed, it may lead to death and major injury.**
- **The reversing radar is not a device**

**used to relieve the driver's attention, but a reversing aid device.**



**If the sound volume is too high, you may not hear the buzzer alarm sound of the reversing radar.**

### **Working principle**

#### **Principle of ultrasonic ranging**

By transmitting and receiving ultrasonic waves, we can calculate the distance of obstacles by using the spreading speed of ultrasonic waves and the time difference between transmission and reception.

## Self-check function

After the reversing gear is put on, the reversing radar system enters self-check;

If the radar controller is disconnected, it will not beep;

If reversing radar system functions work normally, beep once;

If the function of one probe is abnormal, beep twice;

If the function of two probes is abnormal, beep three times;

If the function of three probes is abnormal, beeps four times;

If all four probes are abnormal, beep five times.

In order to ensure the effectiveness of reversing assistance, if the system is abnormal, please check and repair it as soon as possible. The abnormal function may be caused by the damage of the reversing radar system, the wrong wiring, or disconnection.

## Detection range and alarm mode of radar

:

When the radar detects an effective obstacle in the detection range, in order to give the driver a better prompt, the buzzer will give different alarm sounds according to the distance of the obstacle. The details are as follows:

<b>Segmen</b>	<b>Obstacle</b>	<b>Buzzer</b>	<b>Buzzer</b>
---------------	-----------------	---------------	---------------

<b>t</b>	<b>distance</b>	<b>mode</b>	<b>frequency</b>
A	180cm~220cm	Long intermittent sound	1HZ
B	150cm~180cm	Short intermittent sound	2HZ
C	90cm~150cm	Fast intermittent sound	4HZ
D	50cm~90cm	Rapid intermittent sound	8HZ
E	50cm±5cm Within 50 cm ± 5 cm	Long sound	Long sound

According to the reflection principle of ultrasonic waves by objects, whether the reflected waves can be captured by radar is related to the angle, size, surface material, and distance of the reflecting surface. For example, telephone poles, pedestrians, vehicles, and walls can be effectively detected. However, the following types of obstacles are not easy to be detected.

Too small objects such as barbed wire and ropes.

Small stones too low on the road.

Soft objects, such as cotton, sponges, and objects that can absorb sound waves, including snow.

The radar surface is frozen or stained with dirt, dust, and snow.

## **False alarm**

:

The buzzer may give an error alarm under the following circumstances:

Driving or reversing at low speed on bumpy roads, gravel roads, and grass. When a radio or antenna with ultra-high power output is installed and used, the sound wave (or its harmonic wave) generated by it will cause the same frequency interference when the frequency is close to the working frequency of the sensor.

The horns of other cars. Sounds from the motorcycle engine, gas brake, and so on are very close to the sensor, and their frequency is close to the working frequency of the sensor, which may lead to a false alarm.

## Simple troubleshooting

If there is no alarm even when approaching obstacles, please check the following points.

<b>Items for check</b>	<b>Solutions</b>
Is there snow or mud attached to the upper surface of the radar?	Wipe with a cloth or wash away with water (low water pressure)
Is the radar surface frozen?	Sprinkle warm water on the radar to thaw it
Do you park your car for a long time in hot or cold weather?	Reversing radar may not work above 80 °C or below -30°C
Is there a large area of smooth surface (such as the glass wall) behind obstacles (within radar detection range)?	The smooth surface has a strong reflection on the ultrasonic wave of radar, which leads to the misjudgment of radar.

If the above points can't be solved, please contact the professional maintenance service station.

When there is no snow or mud attached to the radar, no freezing, or no obstacles when reversing, the buzzer sounds rapidly, please contact the professional maintenance service station.

## **Maintenance**

Please keep the radar surface clean. If the radar surface is stained with dirt and dust, please wipe it with a cloth or wash it with water (low water pressure) to clean the radar surface.



## Warning

---

- You can't flush the radar with a high-pressure water gun.
  - Do not squeeze or impact the radar surface.
- 

## Reversing image

Turn the ignition switch to ON gear, and shift the shift lever to reverse gear (R gear). If the multimedia is not turned on, the multimedia will automatically turn on and automatically enter the reversing image interface, which is convenient for the driver to check the tail of the container; if the multimedia has been turned on, the

multimedia will automatically switch to the reversing image interface to display the reversing image.

## Repair and maintenance

### Maintenance schedule

In order to maintain safe and economical driving, regular periodic inspection and maintenance should be carried out in accordance with the recommended items in this chapter. In order to ensure the safety and economy of driving, we should entrust our special maintenance station to carry out regular inspection and maintenance according to the maintenance schedule.

### Maintenance operation

Check and repair or replace as needed.

A: Adjustment.

R: Replace.

T: Tighten according to the specified torque.

L: Lubrication.

When performing the inspection of the following items, please check the daily inspection items together.

The symbol "\*" indicates the following:

Maintenance should be carried out more frequently under severe driving conditions. Please refer to this chapter "Periodic Maintenance Table under Severe Conditions."

## Maintenance schedule

Calculated by odometer readings or months, repair and maintain according to the first maintenance cycle.

<b>Maintenance type</b>	<b>First maintenance</b>	<b>Regular maintenance</b>
Maintenance period	5000km or 3 months	20,000 km or 6 months
Change oil	•	•
Change oil filter or filter element	•	•
Check and adjust valve clearance	•	•
Replace fuel filter core		•
Check the coolant capacity and fill it up	•	•

Check and fasten cooling line clamps	•	•
Tightening intake lines, hoses and flange connections	•	
/ Cleaning/replacing main filter element of air filter	When the indicator light is on, clean the main filter element of the air filter	
Replace the main filter element of the air filter	Replace when the intake resistance exceeds the maximum limit (6kpa)	
Check and fasten the belt	•	•
Check the booster bearing clearance	Every 120000km	
Check and adjust clutch stroke	•	•
Urea pump filter element		•

Urea nozzle gasket	Every time the urea nozzle is removed,	
Cleaning urea tank and filter element of urea tank		•
Cleaning of sensor filter screen in urea tank		•
Cleaning of filter screen of urea pump inlet pipe		•

## Maintenance schedule

I: Check, clean and correct or replace as necessary. A: Adjustment. R: Replace. T: Tighten to the specified torque. L: Lubrication.

Maintenance period	Month	3	4	5	6	7	8	9	10	11	12	13	14	15
	* 1.000 kilometres	3	5	10	15	20	25	30	35	40	45	50	55	60
Clutch														
Clutch fluid	Replace every 40,000 kilometers or 12 months	I								R				
Clutch pedal stroke and free stroke	Check every 5000 kilometers or 3 months		I	I	I	I	I	I	I	I	I	I	I	I
Transmission														
Transmission inspection	Check every 3 months	I			I			I			I			I
Transmission lubricating oil 5J30T5J38TC6J45TC6J50T/55TC6J75T8J S75TF6JZ45BM (AMT)	General lubricating oil: Replace the lubricating oil every 5000 km or 3 months for the first time and every 50000 km or 12 months thereafter		R											R

## Maintenance schedule

I: Check, clean and correct or replace as necessary. A: Adjustment. R: Replace. T: Tighten to the specified torque. L: Lubrication.

Maintenance period	Month	3	4	5	6	7	8	9	10	11	12	13	14	15
	* 1.000 kilometres	3	5	10	15	20	25	30	35	40	45	50	55	60
Transmission lubricating oil 5J30T5J38TC6J45TC6J50T/55TC6J75T8J S75T	Long-lasting lubricating oil: Free of initial insurance, replaced in the next 300000 kilometers or 36 months, whichever comes first													
Transmission lubricating oil F6JZ45BM (AMT)	Long-lasting lubricating oil: Free of initial insurance, replaced in the next 300000 kilometers or 24 months, whichever comes first													
Variable speed control soft cable	Adjust every 6 months				A						A			
Drive shaft														
* * Universal joints and intermediate	3000 km for the first time, and then lubricate every 20000 km or 6 months					L				L				L

## Maintenance schedule

I: Check, clean and correct or replace as necessary. A: Adjustment. R: Replace. T: Tighten to the specified torque. L: Lubrication.

Maintenance period	Month	3	4	5	6	7	8	9	10	11	12	13	14	15
	* 1.000 kilometres	3	5	10	15	20	25	30	35	40	45	50	55	60
supports														
Looseness of connecting parts	For the first time, 3,000 kilometers, and then every 20,000 kilometers or 6 months					I					I			
Excessive wear of splines	Check every 20,000 kilometers or 6 months					I				I				I
Looseness of bearings and connecting parts	Check every 20,000 kilometers or 6 months					I				I				I
Rear axle														
Rear axle gear oil (ordinary oil)	5000 km or 3 months for the first time, and every 50000 km or 12 months thereafter											R		
Rear axle gear oil (long-acting oil)	Free of initial insurance, replaced in the next 300000													

## Maintenance schedule

I: Check, clean and correct or replace as necessary. A: Adjustment. R: Replace. T: Tighten to the specified torque. L: Lubrication.

Maintenance period	Month	3	4	5	6	7	8	9	10	11	12	13	14	15
	* 1.000 kilometres	3	5	10	15	20	25	30	35	40	45	50	55	60
	kilometers or 36 months, whichever comes first													
Front axle														
* * Steering kingpin and tie rod ball head	Lubricate every 3 months	L			L			L			L			L
Clearance between steering knuckle and front axle	Check every 10,000 kilometers or 6 months			I		I		I			I			I
Steering system														
Loose and damaged steering mechanism	Check every 6 months	T			I						I			
Power steering oil level	Replace 5,000 km for the first time and replace it every 50,000 km or 12		R											R

## Maintenance schedule

I: Check, clean and correct or replace as necessary. A: Adjustment. R: Replace. T: Tighten to the specified torque. L: Lubrication.

Maintenance period	Month	3	4	5	6	7	8	9	10	11	12	13	14	15
	* 1.000 kilometres		3	5	10	15	20	25	30	35	40	45	50	55
	months thereafter													
Clearance of steering wheel	For the first time, 3000 kilometres, and then every 10000 kilometres or 3 months		I	I	I	I	I	I	I	I	I	I	I	I
Steering function	Check every 10,000 kilometres or 3 months			I		I		I		I		I		I
Wheel alignment	Check every 40,000 kilometres or 24 months									I				
Main brake														
Brake fluid	Replace every 40,000 kilometres or 12 months									R				
* * Wear and clearance of friction linings and brake discs	Check every 10,000 kilometres or 3 months			I		I		I		I		I		I

## Maintenance schedule

I: Check, clean and correct or replace as necessary. A: Adjustment. R: Replace. T: Tighten to the specified torque. L: Lubrication.

Maintenance period	Month	3	4	5	6	7	8	9	10	11	12	13	14	15
	* 1.000 kilometres	3	5	10	15	20	25	30	35	40	45	50	55	60
* * Wear of friction pads and brake discs of disc brakes	Check every 10,000 kilometers or 3 months			I		I		I		I		I		I
Stroke and free stroke of the brake pedal	Check every 10,000 kilometers or 3 months			I		I		I		I		I		I
Looseness and damage of the connection between pipeline and soft track	Check every 10,000 kilometers or 3 months	T		I		I		I		I		I		I
Wear and clearance of friction lining	Check every 10,000 kilometers or 6 months			I		I		I		I		I		I
Wear and damage of brake drum	Check every 40,000 kilometers or 12 months			I		I		I		I		I		I
Desiccant in air dryer (drying cylinder)	Check every 10,000 kilometers or 6 months			I		I		I		I		I		I
Function of control valve system	Check every 40,000 kilometers or 12 months			I		I		I		I		I		I

## Maintenance schedule

I: Check, clean and correct or replace as necessary. A: Adjustment. R: Replace. T: Tighten to the specified torque. L: Lubrication.

Maintenance period	Month	3	4	5	6	7	8	9	10	11	12	13	14	15
	* 1.000 kilometres	3	5	10	15	20	25	30	35	40	45	50	55	60
Excessive wear of wheel brake cam	Check every 10,000 kilometers or 3 months	A		I		I		I		I		I		I
Brake chamber push rod stroke	Check every 40,000 kilometers or 12 months									I				
Maintenance of adjusting arm	Lubricate every 20,000 kilometers or 12 months					L				L				L
Wear and damage of ratchet structure	Check every 10,000 kilometers or 12 months			I		I		I		I		I		I
Suspension device														
Damage of leaf spring	Check every 10,000 kilometers or 6 months			I		I		I		I		I		I
U Leaf spring U bolt	Check every 5000 kilometers or 3 months	I	I	I	I	I	I	I	I	I	I	I	I	I
	Check every 10,000			I		I		I		I		I		I

## Maintenance schedule

I: Check, clean and correct or replace as necessary. A: Adjustment. R: Replace. T: Tighten to the specified torque. L: Lubrication.

Maintenance period	Month	3	4	5	6	7	8	9	10	11	12	13	14	15
	* 1.000 kilometres	3	5	10	15	20	25	30	35	40	45	50	55	60
Looseness and damage of installation parts	kilometers or 3 months													
Oil leakage of shock absorber	Check every 10,000 kilometers or 6 months			I		I		I		I		I		I
Looseness of shock absorber mounting	Check every 10,000 kilometers or 6 months			I		I		I		I		I		I
Front and rear leaf spring pins	Lubricate every 5,000 km or 6 months		L	L	L	L	L	L	L	L	L	L	L	L
Wheels														
Wheel nut	Tighten every 5000km or 3 months	T	T	T	T	T	T	T	T	T	T	T	T	T
Damage to the wheel	Lubricate every 12 months										L			
Hub bearing grease	Replace it every 10,000 kilometers or 6 months			R		R		R		R		R		R

## Maintenance schedule

I: Check, clean and correct or replace as necessary. A: Adjustment. R: Replace. T: Tighten to the specified torque. L: Lubrication.

Maintenance period	Month	3	4	5	6	7	8	9	10	11	12	13	14	15
	* 1.000 kilometres	3	5	10	15	20	25	30	35	40	45	50	55	60
Tire pressure and damage	Check every 1000 kilometers or 3 months	I			I			I			I			I
Electrical installations														
Specific gravity of battery electrolyte	Check every 6 months				I						I			
Air conditioning filter screen	Check every 6 months				I						I			
Others														
Car lights, horns, windshields, wipers and scrubbers	Check every 6 months				I						I			
Bolts and nuts on frame and body	Check every 24 months	I												

## Maintenance guide

S/N	System	Operation content	Thread specification	(N.m) Tightening torque (N.m)
1	Front suspension	Front suspension U-bolt	M16×1.5	207~230
2		Front leaf spring rear lug bolt	M18×1.5	300~335
3	Rear suspension	Rear suspension U-bolt	M20×1.5	423~470
4	Direction of rotation	Steering gear output shaft plumbing arm lock nut	M30×1.5	280~320
5		Steering gear and its bracket, frame connecting nut	M12×1.75	120~150
6		Steering tie rod ball nut	M18×1.5	216~264
7		Steering drag link ball nut	M18×1.5	216~264
8		Connecting joint between steering gear and steel pipe	M16×1.5	40~60
9		Connecting joint between steering pipe and steel pipe	M18×1.5	40~60

10		Steering wheel lock nut		48~58
11		Oil outlet joint of the oil pump connected with the steering oil pump	M20×1.5	50~70
12		Oil inlet joint of the oil pump connected with the steering oil pump	M22×1.5	60~90
13	Drive shaft	Drive shaft flange connecting bolt	M14×1.5	210~230
14	Wheels	Wheel nut	M20×1.5	390~470

Note: All parts of the vehicle connected with fasteners, except for the tightening torque of important parts specified above, shall comply with QC/T518.

## Periodic maintenance schedule under severe conditions

Poor driving conditions:

A: Frequent short-distance round trips;      B: Driving on rough roads;      C: Driving on dusty roads;

D: Driving in cold seasons or on salty roads.

Item	Period	Condition				
		A	B	C	D	A-D
Engine oil	Replace every 10,000 kilometers			•		
Engine oil filter	Replace every 10,000 kilometers			•		
Air filter element	Replace every 40,000 kilometers			•		
Looseness and damage of steering system	Check every 3,000 kilometers		•			
Universal joint grease	Lubricate every 10,000 kilometers		•			
Transmission oil (normal oil) 5J30T, 5J38T	Replace every 10,000 kilometers	•	•			
Transmission oil (normal oil) C6J45T, C6J45T, C6J50T/55T, C6J75T, 8JS75T, F6JZ45BM	Replace every 20,000 kilometers	•	•			
Transmission oils (long-term oil) 5J30T, 5J38T, C6J45T, C6J50T/55T, C6J75T, 8JS75T, F6JZ45BM	Replace every 30,000 kilometers	•	•			
Rear axle gear oil (ordinary oil)	Replace every 20,000 kilometers		•			

	kilometers					
Rear axle gear oil (long-acting oil)	Replace every 30,000 kilometers		•			
Wear of brake friction lining and brake drum	Check every 5,000 kilometers	•	•	•		
Wear of friction facing and brake disc of disc brake	Check every 5,000 kilometers	•	•	•		

## Replacement of automatic slack adjuster

### Installation steps of automatic slack adjuster

Before installation, ensure that the brake chamber push rod is in the initial position. When the spring brake chamber is equipped, keep the air pressure of the brake system above 0.6 MPa to make the push rod of the air chamber in the initial position.

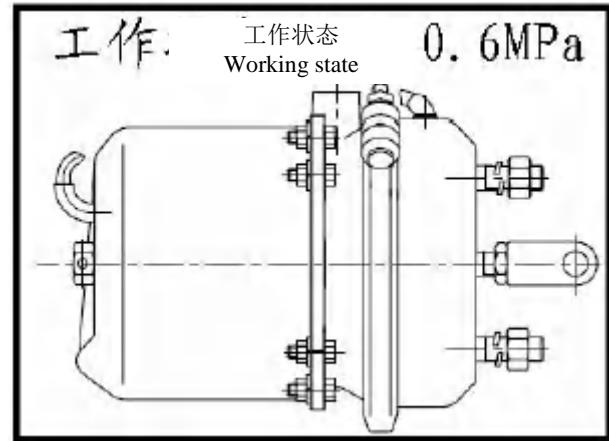

Push the control arm in the braking direction (the arrow on the control arm indicates the pushing direction) to the bottom, and then install the adjuster on the camshaft. The arrow direction on the housing shall be consistent with the braking direction, that is, the direction of the adjuster pushed outward by the brake chamber push rod. When the

control arm is installed, the control arm should be in the shaded range as shown in the figure, and the housing should be marked. Otherwise, the interference between the control arm and the housing will occur during braking.

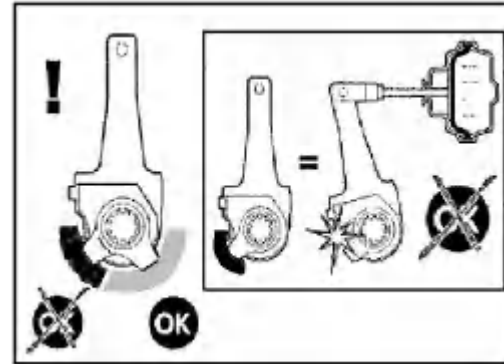
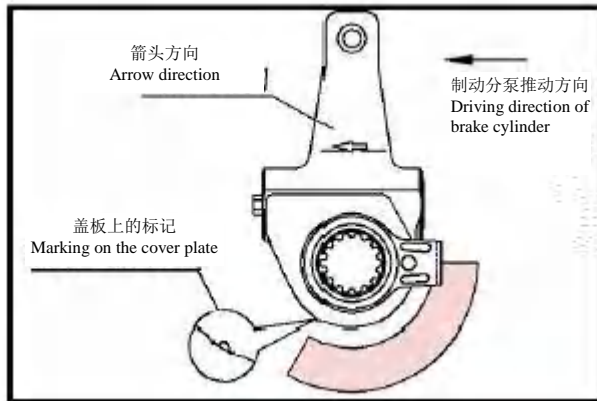

Rotate the worm hexagon at the end of the adjuster clockwise with the SW12 wrench, so that the hole of the adjuster is naturally aligned with the positioning hole of the U-shaped fork of the air chamber push rod. Then, easily insert the parallel pin into the U-shaped fork hole, and lock the cotter pin.

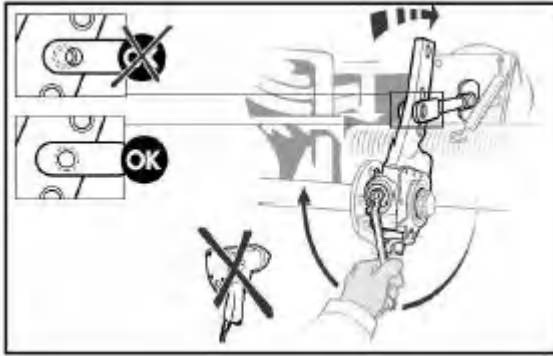

### Warning



**Do not use electric wrenches and pneumatic drills!**

Fix the adjusting arm on the camshaft with the spacer, bolt or gasket, and circlip. At this time, ensure that the axial clearance of the adjusting arm is

$A = (0.50 - 2.00) \text{ mm}$ .

① Push the control arm in the direction of the arrow (there is an arrow on the control arm indicating the driving direction) until it cannot be pushed.

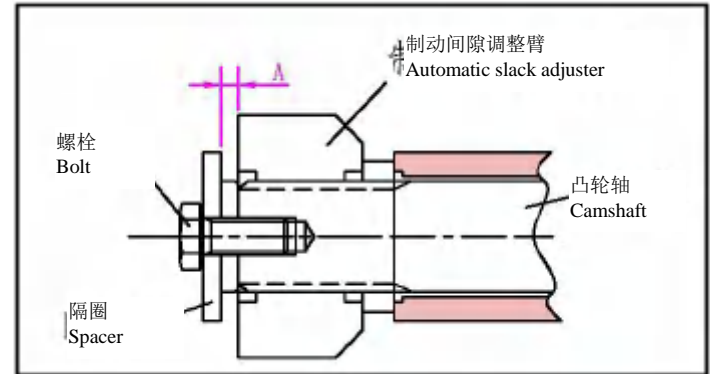

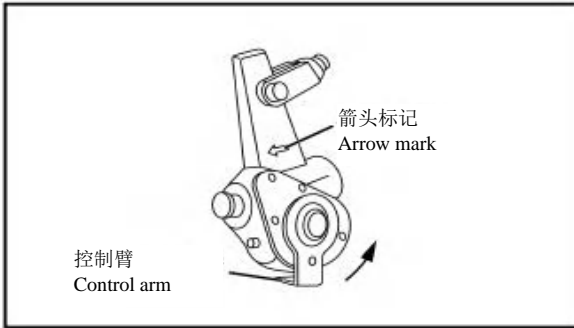
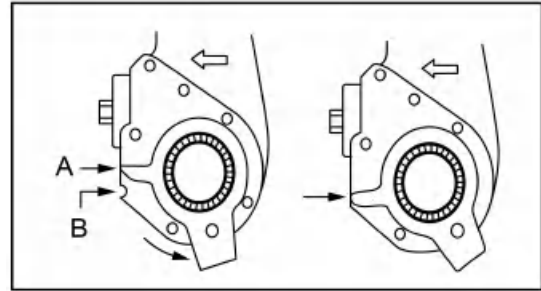
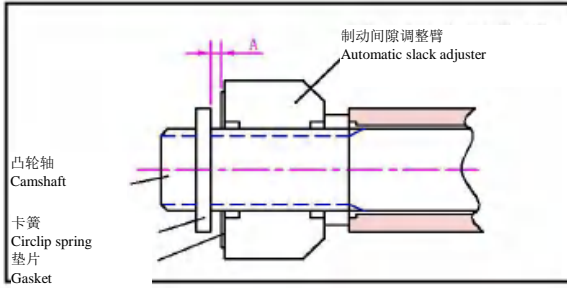

③ Or the notch on the control arm is aligned with that on the cover plate of the control arm.

② At this time, the pointer on the control arm shall point to the opening.

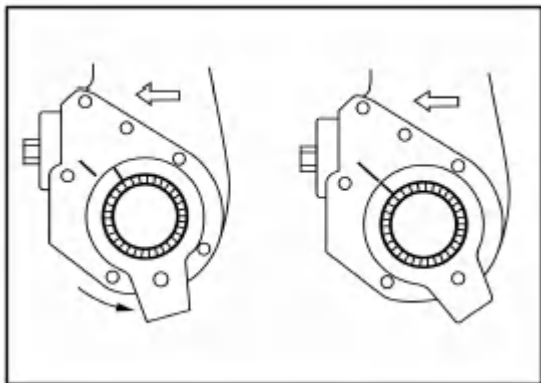

④ Then install the adjuster bracket, and fasten the control arm on the positioning bracket.

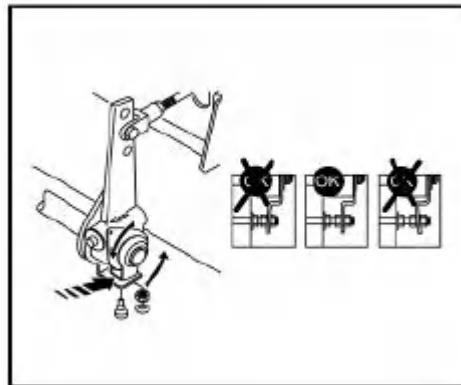

Clearance adjustment: Rotate the worm hexagon of the adjuster clockwise with a wrench until the friction plate contacts the brake drum, then turn the worm hexagon counterclockwise 3/4 times (clicking sound will be heard when rotating in reverse).

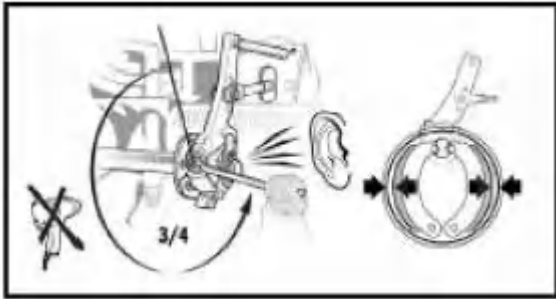

After applying several brakes, the brake clearance is automatically adjusted to the normal range. The adjustment function can be observed by automatically rotating the worm hexagon clockwise at the end of braking, and the installation process is finished.

### **Removal steps of automatic slack adjuster**

Remove the cotter pin and cylindrical bolt connected on the brake chamber to separate the brake chamber from the adjuster.

Remove the axial positioning spacer and bolt (or gasket and circlip) at the upper end of the camshaft.

Rotate the worm hexagon counterclockwise with the SW12 wrench (the torque required during rotation is large, and a clicking sound will be heard) until the adjuster handle is disengaged from the U-shaped fork of the air chamber push rod.

Remove the supporting bolts, nuts, and gaskets connecting the control arm with the positioning bracket. Finally,

remove the adjuster from the camshaft.

## Maintenance of automatic slack adjuster

The adjuster shall be filled with 2# lithium grease every 20,000 km.

When braking is weak, it is recommended to detect the counterclockwise torque of the worm hexagon of the adjuster. After one rotation, if the measured minimum torque is less than 18 N.m, it indicates that the adjusting arm has been damaged, and the adjusting arm assembly must be replaced in time.

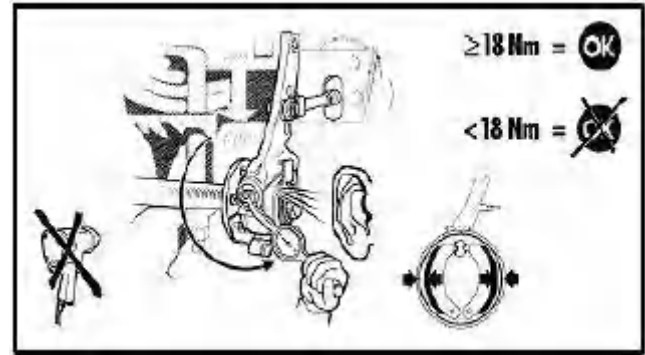

## Possible errors in installation

Error 1: Fix the control arm and positioning bracket first, and then connect the U-shaped fork of the adjuster and the air chamber push rod.

Correction method: Contrary to the correct installation sequence, follow the above correct installation steps.

Error 2: Try to forcibly insert the parallel pin when the pin hole of the U-shaped fork shaft of the air chamber push rod is not aligned with the hole on the adjuster handle.

Correction method: Rotate the worm hexagon clockwise and counterclockwise. When the hole on the adjuster handle is aligned with the pin hole of the U-shaped fork shaft naturally, insert the parallel pin into the U-shaped fork hole easily and lock the cotter pin. During installation, if the push rod of the air chamber is too long, and the U-shaped fork holds the adjuster, the U-shaped fork can be rotated back for a certain distance.

Error 3: Fix the control arm when it is not pushed into place.

Correction method: Push the control arm in

the direction of the arrow on the control arm until it can't be pushed, and then fix it.

Error 4: Always use a wrench to screw the worm hexagon.

Correction method: Because the structural feature of the adjuster is that its clearance is automatically adjusted, it is required to rotate the worm hexagon during installation, disassembly, and detection, otherwise, it will seriously affect the service life of the product.

## Front axle brake air chamber intake hose replacement

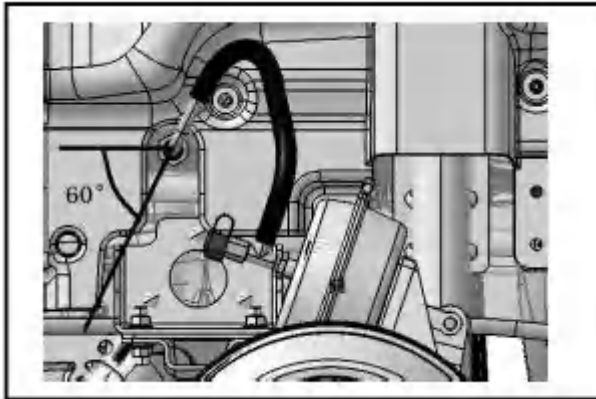

To replace or remove the intake hose of the front axle brake air chamber, ensure that the steel pipe part of the reassembled intake hose faces the

vehicle with an angle of  $60^{\circ} \pm 5^{\circ}$ .

## Precautions for using air brake ABS

1. Do not flush ECU with water;
2. Do not measure ECU with multimeter;
3. When charging the battery with external high voltage, disconnect the ABS;
4. Turn off the power supply when disassembling and assembling each component;
5. Disconnect ABS when the vehicle is welded;
6. Always check whether the voltage of the generator is stable;
7. Replace broken ABS indicator lamp in time;
8. Do not change the capacity of insurance at will;
9. ABS only works when the wheels tend to be locked due to emergency braking. Generally speaking, ABS works like a driver's quick and frequent "point braking", but the driver's "point braking" frequency cannot be compared with

ABS in any case, while ABS can change 3–5 times in 1s;

10. When a vehicle equipped with ABS encounters emergency braking in danger, first step down the clutch quickly, then step on the foot braking wildly, and still turn the steering wheel to make the vehicle avoid obstacles.



### Warning

---



**When the vehicle speed is too high or the turn is too sharp, if the vehicle brakes too fast and too hard, the vehicle will still sideslip. Therefore, even if the vehicle is equipped with ABS, it still needs to drive carefully.**

---

### Coolant level

Overheating of the engine can cause engine fault or damage. In order to avoid the above phenomenon, the coolant level must be checked regularly.

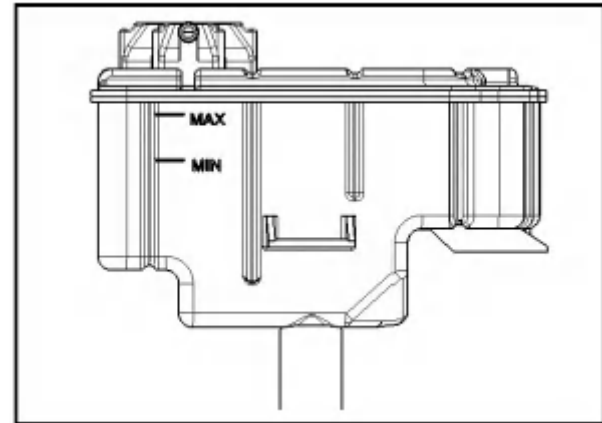

### Warning

---



---

Care should be taken to avoid coolant overflowing from the auxiliary radiator during replenishment.



If it is not necessary, please do not remove the water filler cover of the auxiliary radiator.



Check the coolant level after the engine cools down.



Do not use the preservatives or additives used to increase cooling that have not been certified by our Company in the cooling system.



---

The coolant is long-term antifreeze,

---

and the model is LEC-II-40.



Antifreeze can be selected according to the ambient temperature in different areas. Users need to confirm that the selected antifreeze meets the minimum ambient temperature requirements in the use area to prevent the liquid from freezing.



The concentration range of antifreeze used is 20%–60%. If the concentration exceeds 60%, the engine may overheat, and the anticorrosion characteristics will be reduced when the concentration falls below 20%.



---

**To replace coolants of different brands or models, it is necessary to flush the interior of the cooling system including radiators.**



**When there is scale in the cooling system, before adding new antifreeze, use the water tank cleaning agent to remove scale, otherwise the additive in antifreeze reacts with scale to produce flocs.**



**It is forbidden to mix different types of antifreeze.**



**It is strictly forbidden to add tap water or river well.**



---

**The antifreeze replacement cycle is 2 years. If the antifreeze is found to be discolored and muddy, the antifreeze shall be replaced.**



**Do not step on the auxiliary radiator.**

---

## Steering wheel

Turn the steering wheel to the left and right until the tires start to move to check the clearance of the steering wheel. The standard gap should be in the range of (0–37) mm.

At this time, measure the clearance of the front wheel along the periphery of the steering wheel with the front wheel facing forward.

In addition, swing the steering wheel forward, backward, left, and right to check the installation clearance of the steering wheel and whether it is loose.

When driving a vehicle, check whether there is difficulty in steering, vibration, being pulled to one side, etc.



## Warning

---



**In case of excessive clearance, looseness, and other abnormalities of steering mechanism parts, check the steering mechanism at the Special Repair Station of our Company immediately.**

---

## Liquid level of clutch fluid

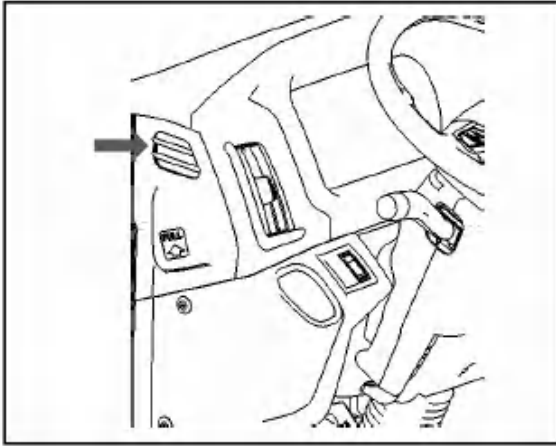

Check that the liquid level of the clutch fluid is between the "MAX" and "MIN" level marks on the cup body. If the level is below the "MIN" mark line, fill it with the recommended brake fluid.

### Free stroke of clutch pedal

:

The standard values are:

- ① Free stroke: (15–25) mm;
- ② Height from pedal center to floor: (160–165) mm

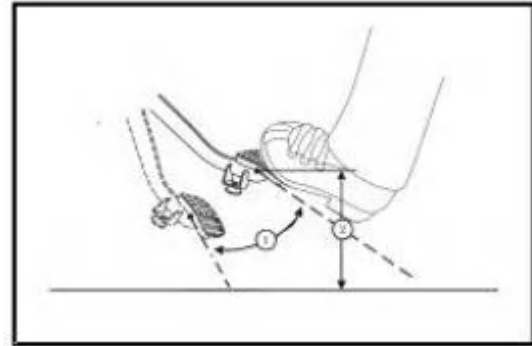

### Free stroke and allowance of brake pedal

The standard values are:

- ① Free stroke: (10–15) mm;
- ② Height from pedal center to floor: (140–145) mm.

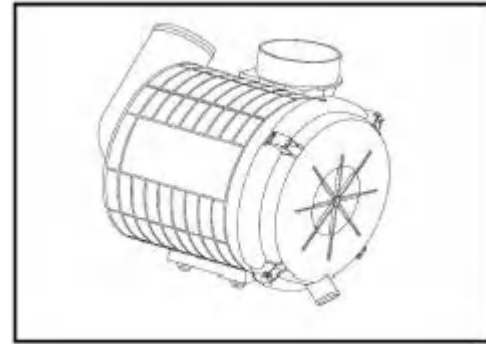
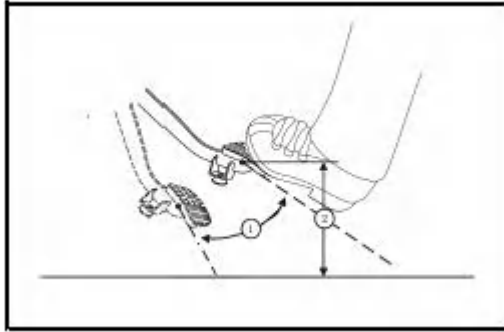

If the blocked air filter element is used, it will not only reduce the output power of the engine, but also increase the fuel consumption and emit black smoke. In severe cases, it can break through the filter paper to cause the piston assembly of the engine to wear. Therefore, the air filter shall be maintained according to the following methods.



### Attention

### Regular maintenance of air filters

- **When replacing the filter element, be sure to use the original air filter element, and ensure sealing when assembling.**

- **If the indicator is on or reaches the maintenance trip, it should be maintained in time and replaced according to the maintenance trip. When replacing, the blade ring cannot be installed backward (with this configuration).**

- **If the vehicle is used in a dusty environment, shorten the maintenance trip in accordance with the situation.**

## **Disassembly of air filter element**

1 Pull off the buckle

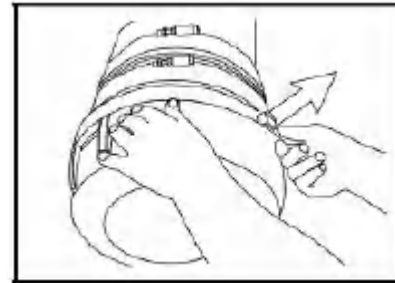

2 Pull out the lower housing outward.

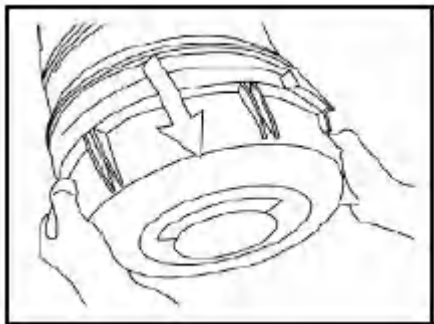

3 Pull out the filter element outward.

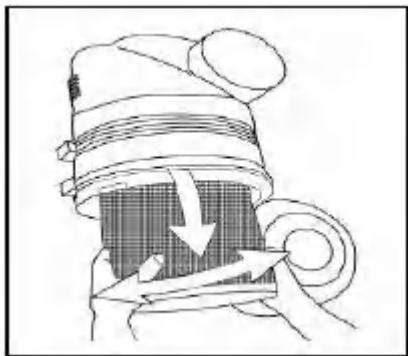

4 Press the filter element into the upper housing of the air filter.

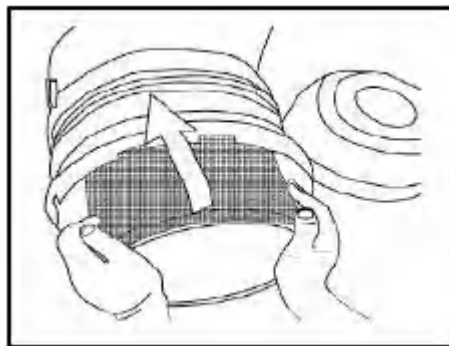

5 Install the lower housing.

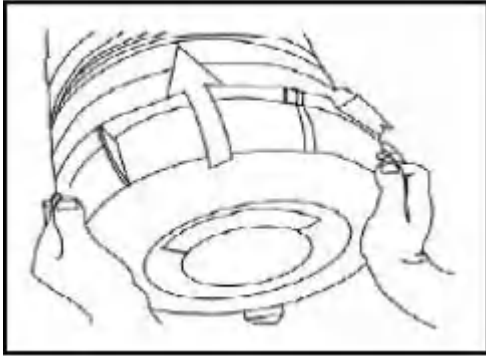

### Warning

---

- **Take and place the filter element carefully so as not to damage it.**

---

### Air filter maintenance precautions

Disassemble it according to the figure, and install it reliably after maintenance.

Take and place the filter element carefully so as not to damage it.

At the same time, check whether the dust bag of the air filter accumulates dust and is blocked, and rinse it with water if necessary.

### Cleaning of air filter housing, cap, and air passage

Wipe the dust inside the air filter housing, outer cap, and gasket surface clean, and wipe the dust and oil stain in the air passage clean.

### Cleaning of filter element

After removing the empty filter element from the air filter, when the filter element is polluted by dust but in a dry state, pat the end face to make dust fall, or use compressed air to blow back (from inside to outside).

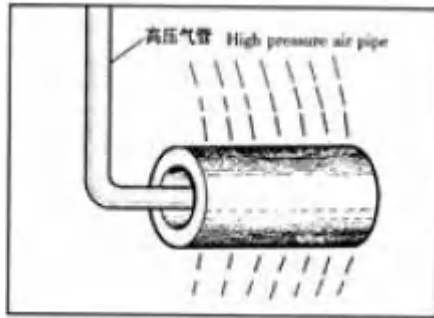

**Warning**

---

- **Never use the engine without an air filter, otherwise, dust and impurities entering the engine will lead to early**

---

---

**wear of the engine!**

---

## Intercooler cleaning

1. Clean up external stains according to the situation.

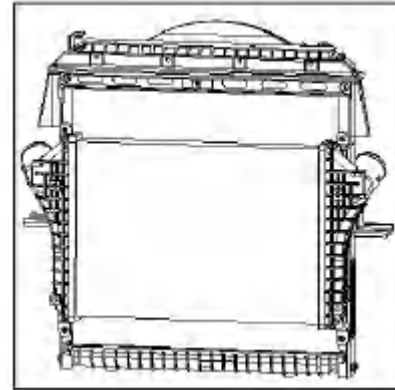

2. Clean the engine oil inside the intercooler with

gasoline.

### **Maintenance of urea tank filter element**

Every 120,000 km, the filter element in the urea tank needs to be maintained.

#### Disassembly

1. Turn the injection unit counterclockwise for a quarter of a turn as shown below;

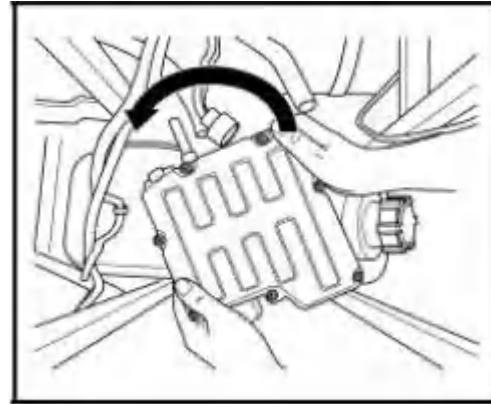

2. Slowly lift the injection unit and liquid level sensor out of the urea tank.

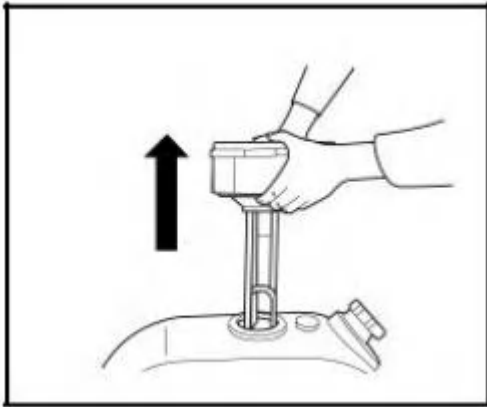

3. As shown in the following figure: ① Squeeze the buckles inward; ② Disassemble the buckles; ③ Pull out the filter.

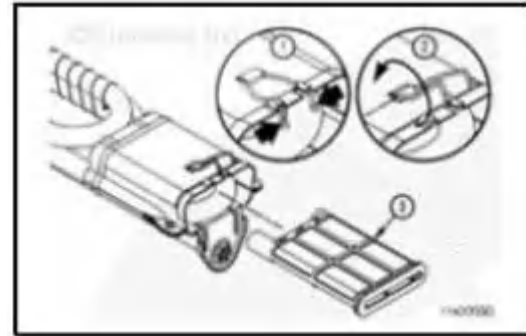

### **Maintenance and inspection**

Check the filter and sealing ring of the reservoir for pollution and damage. If there is any damage, the injection unit filter should also be checked. After checking, replace the reservoir filter with a new one.

### **Installation**

Contrary to the removal process, press the filter, fasten the buckle, and tighten the injection unit clockwise.

### **Cleaning of filter screen in cooling water pipeline of urea tank sensor**

Hold the filter screen buckle outward to pull out the filter screen.

Rinse the filter screen by the water source, and wash the stains on the filter screen with a glue brush.

Install the filter screen, hold the filter screen buckle by hand, and force it into the water pipe joint in the vertical direction.

### **Maintenance of urea pump filter element (available in some models)**

1. Unscrew the protective cover counterclockwise, remove the filter screen, and replace the brand-new sealing gasket and filter screen. After operation, tighten the protective cover clockwise.

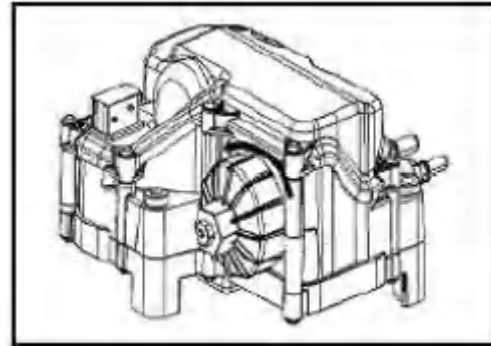

2. Replace the filter screen once every 240000 km or 48 months.

3. The specific replacement interval varies with different applications, but shall not exceed 320000 km.

## Replacement of urea pump filter element

### Initial inspection

Check the sealing element of filter cap and the surrounding area of the exhaust port for signs of leakage. Wipe the dust on the surface with a clean wet towel to prevent contamination of the filter element in subsequent steps.

### Disassembly

Use a 38 mm wrench to twist the filter cap counterclockwise ①, pull out the filter balance filter element ②, and pull out the filter element ③.

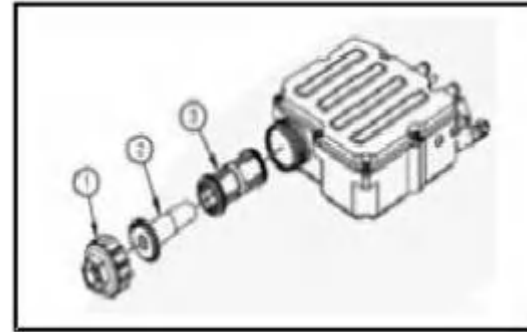

### Replacement and installation

Replace the new filter element and balance filter element. Check the filter cap, and replace it with a new one if it is damaged.

Installation is opposite to removal. Tighten clockwise with a tightening torque of 20 N.m.

## Replacement of oil-gas separator

When the vehicle travels every 60,000 km or 12 months, replace the filter element of the oil-gas separator, whichever comes first.

### Disassembly

Empty the vehicle air system, clean the area around the filter seat, disassemble the air filter clockwise, and clean the sealing surface of the filter seat.

### Replacement

Apply a clean 15W-40 oil to the surface of the oil filter gasket.

## Installation

Tighten the filter counterclockwise until the gasket touches the filter seat surface, then tighten it 3/4 to 1 turn, and start the engine to check for leakage.

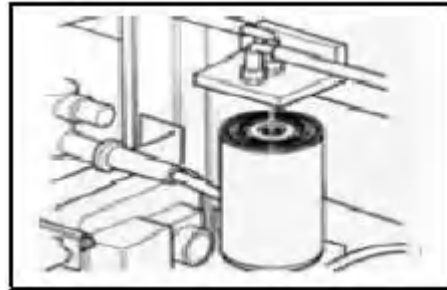

## Air-side cleaning of exhaust treatment fluid injection unit of after-treatment diesel engine

Clean it every 10 months (or every 48,000 km).

## **Initial inspection**

Check the inlet and outlet lines of the DEF injection unit for any signs of leakage. DEF will form a white deposit around the leaking pipe joint. If deposits are found, check whether the DEF pipe joint is damaged.

## **Preparation**

Treat the urea injection unit with a clean damp cloth and warm water plus a mild cleaning agent. Wipe off all contaminants with a clean damp cloth to reduce the risk of contaminants entering the urea injection unit.

## **Rinse**

1. Disconnect the air supply pipe of the urea injection unit, and completely fill the PTFE pipe with warm water.

2. Connect the PTFE pipe filled with warm water in series to the air supply pipe of urea metering pump.

3. Remove the urea nozzle from the exhaust pipe and place it in a clean container.

## **Fuel (gas) system**

1. Check the sealing performance of fuel (or gas) hose joints daily to ensure that the clamp, quick connector, and other locking joints are tightened and sealed in place without oil impregnate and oil leakage (or gas leakage).

2. Daily check that the direction and fixation of fuel (or gas) hose are reasonable, to avoid interference between the hose and surrounding parts, discount, and other phenomena affecting service performance.

3. Under normal use, it is recommended that the reasonable replacement period of fuel (or gas) hose shall not exceed three years (calculated from the production date).

4. In case of cracks and aging on the surface of the fuel (or gas) hose during daily inspection, go to the service station immediately to replace the manufacturer's hose.

## **Engine coolant**

To replace the engine coolant, loosen the

drain valve on the radiator and cylinder to drain the liquid in the cooling system.

The engine cooling system shall be flushed at least once a year to ensure its best cooling effect.

When replacing or refilling the coolant of the engine cooling system, incorrect filling will sometimes cause the coolant to overflow from the neck of the water injection port when the engine and radiator are not full. If the engine is operated in this state, the lack of coolant may cause the engine to overheat. To avoid such a fault, please follow the following precautions when filling coolant:

1. Add the filling port of the coolant auxiliary radiator or from the filling port of the upper water chamber of the radiator (the pressure is covered on the radiator).

2. After filling, let stand for 2 min to observe whether the coolant level of the overflow kettle drops. If the liquid level drops, continue to fill the coolant until the coolant level no longer drops.

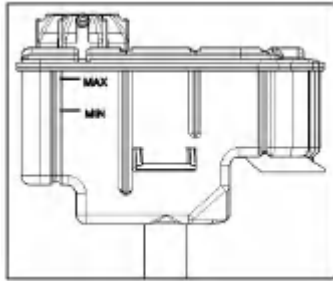

3. Start the engine to 1500 r/min and run for about 3 min–5 min, and observe whether the liquid level of the overflow kettle drops. If the liquid level drops, continue to fill the coolant until the coolant level no longer drops.

4. After fully filling the cooling system, the coolant in the overflow kettle shall be between MIN and MAX level marks.

5. Install and tighten the water injection cover (be sure to tighten the cover to the locked position). Stop the engine, wait until the cooling water temperature drops, and then check the liquid level of the auxiliary radiator again. If the liquid level is found to be insufficient, continue to fill the coolant to the required liquid level.



### Attention

● **Check the coolant regularly, and replace it in time according to the situation to prevent corrosion damage.**

●  
**Do not use water and inferior coolant as engine coolant.**

### **Refrigerant charge quantity of air conditioning system**

Only R134a with  $(450 \pm 20)$  g is used.

:

Refrigerant filling requirements during maintenance:

1. When a small amount of supplementary refrigerant is needed, R-134a refrigerant can be directly charged according to pressure.
2. When the air-conditioning system is repaired, it must be vacuumed after the maintenance is completed, that is, the gauge pressure is  $(-0.095$

MPa $-0.1$  MPa) and kept for 20 minutes without rising, so as to ensure that there is no obvious leakage in the system before filling.

3. Only ZXL100PG can be used for refrigerant oil of air-conditioning system, which capacity is  $(140 \pm 10)$  ml (compressor comes with it). Refrigerant oil shall be properly replenished every time it is repaired or filled with refrigerant.

### **Regular inspection of refrigerant leakage**

Check the pressure of the air conditioning system regularly, and measure the inlet and outlet pressure of the compressor with a pressure gauge: ambient temperature  $(38 \pm 3)$  °C (under the high temperature in summer and sufficient sunshine), idling. The high pressure is  $(1.65 \pm 0.1)$  MPa, and the low pressure is  $(0.2 \pm 0.1)$  MPa. Excessive filling of refrigerant is strictly prohibited.

Items	Content and Object	Inspection time		
		Daily	6 months or 5,000 km	12 months or 10,000 km for the first time
Refrigerant leakage (including oil leakage)	Leakage from piping connection	•	•	
	Leakage of parts (compressor, condenser, evaporator, and liquid storage dryer)			•

## Clutch hydraulic circuit exhaust

If air is mixed into the clutch hydraulic circuit, it will cause the clutch to slip due to incomplete clutch disengagement. Therefore, when it is found that the fluid volume in the clutch oil cup is obviously insufficient and the clutch slips, or when the hydraulic circuit is disassembled, exhaust must be carried out. Exhaust operation shall be carried out by two people together.

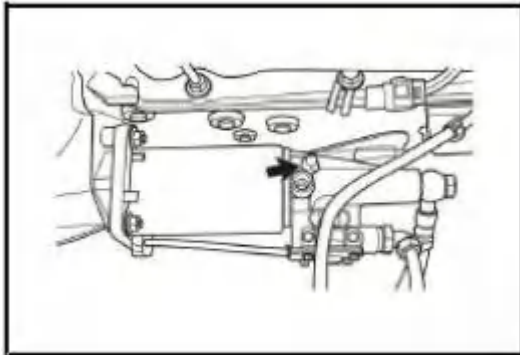

## Bleeding step

Pull up the parking brake manual valve.

Remove the rubber cover from the exhaust plug screw, and wipe the exhaust plug screw clean. Attach the ethylene hose to the exhaust plug screw, and place the other end of the ethylene hose into a transparent container.

Repeatedly press the clutch pedal and keep it depressed.

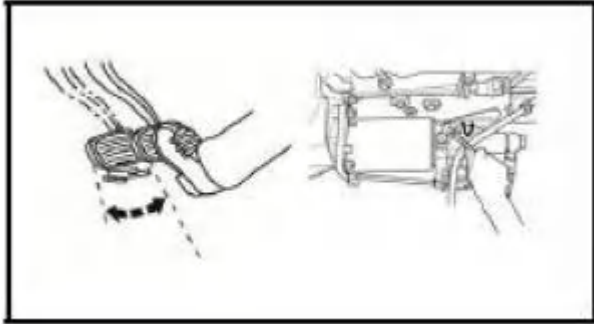

Loosen the exhaust plug screw on the clutch cylinder, drain the clutch fluid with bubbles into the container, then tighten the exhaust plug screw immediately.

Release the clutch pedal slowly. Repeat the above operations until the bubbles in the clutch fluid pumped into the container disappear.

In the process of exhaust, keep the clutch fluid in the clutch oil cup at the specified liquid level. After exhaust, reinstall the rubber cover.

## **Brake adjustment**

When the clearance between the friction lining and the brake drum is too large, the braking safety performance of the whole vehicle will be greatly reduced, because it will increase with the clearance between the friction lining and the drum, resulting in longer braking response time, greater pedal stroke, longer braking distance, lower braking efficiency, and lower safety factor. The clearance of brake friction lining shall be checked and adjusted regularly according to the specified period or actual use.

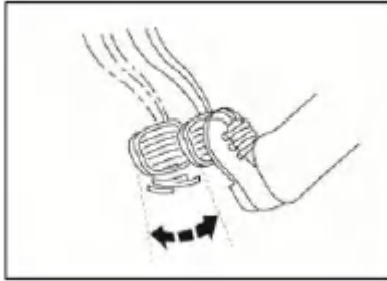

### Wear inspection of brake friction lining

It is unsafe to use the brake system with too large friction lining clearance, because its increase will deteriorate the braking performance, so the brake friction lining clearance shall be checked and adjusted according to the technical maintenance period.

1. Check the friction lining end face from the inspection opening of the brake bottom plate.

2. If the friction lining is worn to a distance of (1–2) mm from the end face marking line, it needs to be replaced.

3. When the brake shoe is worn to the limit, the alarm signal is generated, so it must be replaced in time.

4. Reasonable application range of brake friction pair

Specification	/mm Rivet Limit Range/mm	Status	/mm Reasonable range of brake drum/mm
310*80	8	Double pin front axle	1mm Unilateral 1 mm

310*80	8	Double pin rear axle	
310*100	8	Double pin rear axle	
310*100	8	Wedge rear axle	
310*130	8	Double pin rear axle	
320*160	10.5	Double pin rear axle	
400*155	9.9	Double	2mm Unilateral

		pin rear axle	2 mm
400*180	9.5	Double pin rear axle	
16 16 inch brake caliper	/	2T 2T disk front axle	3mm Reasonable range of brake disc 3 mm

### **Adjustment of brake friction lining clearance**

Make the scale parallel to the push rod, and check the total stroke of the push rod when the brake pedal is pressed.

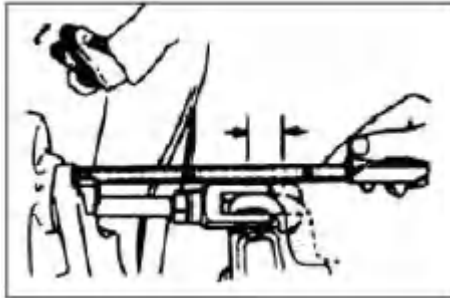

1. Turn the worm shaft on the clearance mechanism clockwise to adjust.

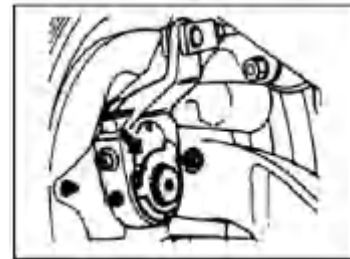
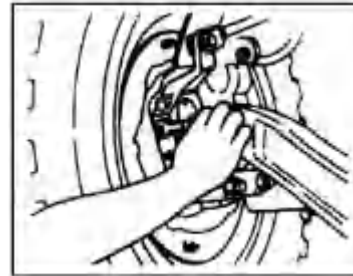

Brake	(mm) Standard Stroke (mm)
Front brake	25 ±5
Rear brake	

When the stroke of the push rod is close to or greater than the service limit, the brake shall be adjusted as follows.

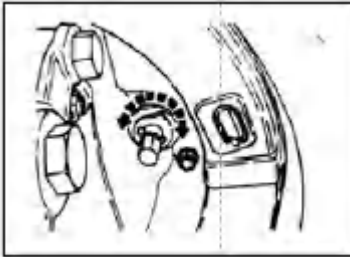

2. When the standard push rod stroke is obtained, adjust the brake friction lining clearance to about 0.3 mm.



### Attention

Brakes without brake clearance self-adjusting need to adjust brake clearance before driving on the road.

Brakes without brake clearance self-adjusting need to adjust brake clearance before driving on the road.

### Inspection and replacement of brake drying tank

Inspection or Maintenance Items	Interval Time
Check whether the dryer exhaust is normal	Weekly
	1.2~3

<b>Replace drying tank</b>	<ol style="list-style-type: none"> <li>1. Every 2–3 years or depending on the frequency of dryer use and the condition of the air compressor.</li> <li>2.</li> <li>2. After replacing or overhauling the air compressor.</li> </ol>
----------------------------	---

:

Method of replacing drying tank:

1. Replace the dryer body and O-ring.
2. Loosen and remove the old drying tank, using a belt or wrench if necessary.
3. Remove the old O-ring from the dryer base.
4. Check and clean the dryer base, repair the damage, and replace it if necessary.
5. Lubricate and install the new O-ring.
6. Lubricate the sealing ring of drying tank.

7. Turn the drying tank by hand until it is tightened, and then tighten it again by hand.

### **Drain the air reservoir**

In order to ensure the safety of braking and prolong the service life of parts of the braking system, water shall be drained frequently in time. Otherwise, it will easily cause aging of rubber parts of brake lines, corrosion of parts, and failure of valves to increase the cost of vehicles.

In winter, it is necessary to increase the number of water drainages. When the temperature is lower than zero, the water in the air reservoir must be drained before collecting the vehicle to prevent icing.

The drain valve is located below each air reservoir, and the water can be drained by pushing up the pull rod of the drain valve.

In winter, it is necessary to increase the number of water drainages. When the temperature is lower than zero, the water in the air reservoir must be drained before collecting the vehicle to prevent icing.

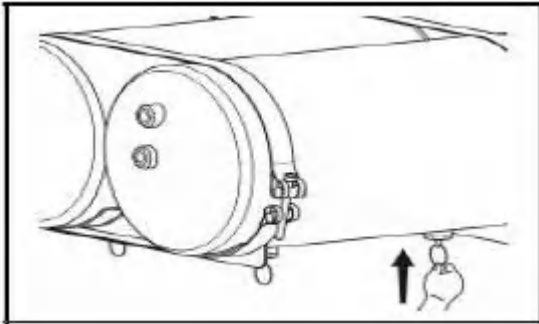

## Rotation of tires

In order to keep the wear degree of each tire uniform and prolong its service life, the front and

rear tire positions shall be changed every 5,000 km to 6,000 km in the order shown in the following figure.



### Attention

- **5000km**  
**For self-locking bolts, retighten them at 5,000 km.**

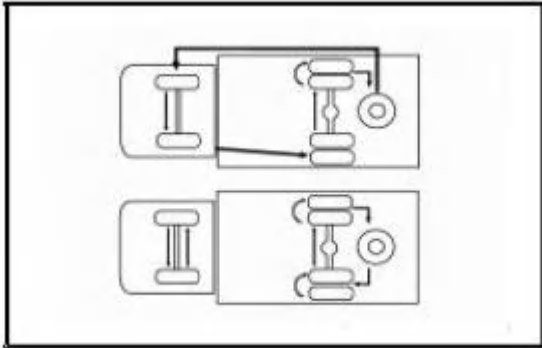

### Inflation pressure of tire

:

The maximum inflation pressure of tires is as follows:

Tire Size	(kPa) Inflation pressure (kPa)	(g) Residual unbalance of wheels (g)
-----------	---	---

7.00R16	670	≤50
7.50R16	770	≤50
205/75R17.5	750	≤50
215/75R17.5	700	≤50
205/75R16	525	≤50
6.50R16	670	≤50
8.25R16	770	≤60
235/75R17.5	775	≤60
8.25R20	930	≤60
265/70R19.5	775	≤60

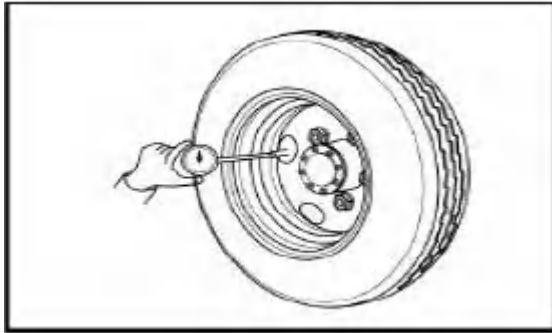

### Attention

- When the tire is in a low-temperature state (the vehicle is parked for more than 3 h or driven for less than 1.6 km), check the tire or carry out tire maintenance.



### Danger

- Do not drive the vehicle unless the tire is inflated according to the specified value and in a safe condition.

- Excessive or insufficient tire inflation pressure will affect the operation of vehicles, resulting in early wear and damage of tires, and even loss of operation control of vehicles.

When measuring the inner tire pressure of the rear wheel of a twin-tire vehicle, use the valve cap wrench of a common tool.

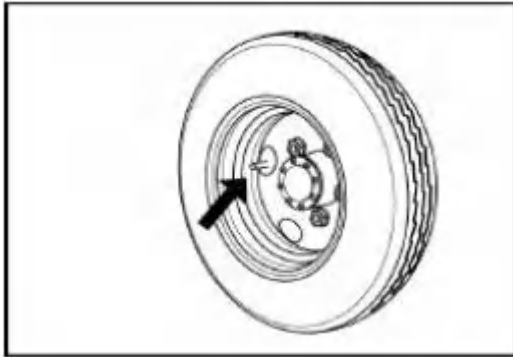

## **Maintenance of battery**

When starting the vehicle, avoid driving the motor for a long time, and the continuous starting time shall not exceed 10s. If it cannot be started within 10s, it shall wait for 1 min to restart, but if it cannot be started after three continuous starts, it shall stop starting. Continuous starting of the engine will seriously affect the performance of

battery.

Check the reliability of the connection between the battery and the vehicle every month, and coat the battery terminals with butter or Vaseline to prevent corrosion. Keep the battery surface clean and dry; keep the connecting line in reliable contact with the battery.

When the engine is not working, try to reduce the use of automobile electrical appliances, and prevent the battery from over-discharging to ensure that the battery is always running at a higher capacity state, so as to prolong the battery life.

During usage, check the charger for voltage (27.6 V–28.4 V) to prevent overcharge or insufficient charge.

In daily use, the generator charges the battery to ensure sufficient battery power. Sometimes, due to large battery discharges, defects in the charging system, or long-term storage, the battery loses power, so the battery shall be removed from the vehicle regularly and replenished in the charging place.

When the vehicle running in winter, it is best to remove the battery for a recharge. Keep the battery voltage above 12.5 V.

Check whether the exhaust hole on the battery cover is ventilated every month. If it is blocked, the generated hydrogen and oxygen cannot be discharged, which will easily cause bulging to affect the service life of the battery.

For dry-charged batteries (liquid-filled batteries), observe the electrolyte level

every month after being used for more than 6 months. If the liquid level drops below the lowest liquid level line (min), detect and adjust the charging voltage to ensure that it is within the range of 27.6 V–28.4 V (charging voltage for diesel vehicles), and then replenish water to the highest liquid level (max):

When the maintenance-free battery is used in the vehicle for about one year, replenish water (pure water or distilled water, do not add acid) properly to the battery through the reserved liquid injection hole.

It is not suitable for power supply, such as electric mattresses, water heaters, preheaters, etc. If it is used, it shall be replenished immediately. You must be familiar with the relevant regulations of battery manufacturers, and have protective measures.



### Attention

- If the parking time of the vehicle is expected to exceed 15 days, disconnect the battery ground wire to reduce the battery self-discharge. Before the delivery of the waiting vehicle, replenish the battery and then load it for use;

- During the parking period, turn on the vehicle for 30 min every month to replenish the battery. Carry out inspection and maintenance every three months, and the terminal voltage of the battery  $\geq 12.5$  V (or the electrolyte density  $\geq 1.26$  g/ml) shall be normal, otherwise, it shall

be replenished in time.

- Before the new vehicle is delivered to the user or the parked vehicle is started, check whether the battery is short of power again. The terminal voltage of the battery is  $\geq 12.5$  V (or the electrolyte density is  $\geq 1.26$  g/ml), otherwise, it shall be replenished in time.

- The two electrodes are disconnected and connected in the following order:

Disconnection: first negative electrode and then positive electrode;

**Connection: first positive electrode  
and then negative electrode.**



**Warning**



**Disconnect the battery after 2  
minutes after the vehicle is turned  
off, otherwise, the OBD fault lamp  
will be lit.**

**Precautions for maintenance-free  
batteries**



**Danger**



**The electrolyte in the battery is  
dilute sulfuric acid, which is a  
harmful liquid to human body, so  
take care to avoid burning skin or  
clothes, especially to prevent  
splashing eyes.**



**In case the battery electrolyte  
splashes on your eyes, wash it off  
with plenty of water immediately,  
and then go to the hospital for  
medical treatment.**



### Attention

● **Waste batteries are hazardous wastes, which contain waste lead, waste sulfuric acid, and other chemical liquids. If they are directly discharged into the natural environment without treatment, the harm caused is extremely serious. Therefore, the waste battery can't be disposed of by yourself, and discarded at will. It shall be sent to a special organization or company. In case of uncertainty, please consult the maintenance center.**

### **Instructions for using lithium iron starting battery**

:

Some models of Weichai New Energy Commercial Vehicle trucks are equipped with lithium iron starting batteries. Now, the applicable scope, emergency starting methods and precautions of lithium iron starting batteries are explained as follows:

#### **1. Scope of application of lithium iron starting battery**

The ambient temperature of the vehicle is  $-15^{\circ}\text{C}$ – $40^{\circ}\text{C}$ , otherwise there is a risk that it cannot be started.

Do not start the vehicle frequently.

It is not applicable to vehicles with long-term power demand after flameout (such as turning on low beam

for more than 20 min).

It is recommended to put the lithium iron starting battery into operation in limited area.

## **2. Emergency starting method of lithium iron starting battery**

The lithium iron starting battery has the function of reserving emergency starting power. When it is used to the reserved value of emergency starting power, it will enter the protection state, and the emergency starting power can only be activated after activation. The operation method is as follows:

Method 1:

Turn the main power switch to the "ON" gear, and turn the vehicle key gear to the "LOCK" gear (or pull out the key) for more than 1 min; then put the vehicle key gear in the "ON" gear, wait for 1 min, release the protection, and the lithium iron starting battery can continue to be used (discharged) to the fully protected state.

Method 2:

Turn the main power switch to "OFF" for more than 1 min, then turn it to "ON", then turn the vehicle key gear to "ON", wait for 1 min, release the protection, and the lithium iron starting battery can continue to be used (discharged) to fully protected state.

Method 3:



### Attention

● **When the lithium iron starting battery is discharged to a fully protected state, it must be charged before being used (discharged). The power value of emergency starting power is low, so long-term use (discharge) at this stage shall be avoided after starting, the vehicle shall be started as soon as possible, and the lithium iron starting battery shall be charged.**

Connection to Bluetooth is activated by mobile phone applet.

### 3. Precautions for the use of lithium iron starting battery

It is not recommended to start frequently. It is necessary to land for 30 minutes for three consecutive starts, and charge the lithium iron starting battery.

If it is not used for more than 10 days, please disconnect the connection between the battery and the equipment to avoid over-discharge of the battery caused by leakage. Before delivering the vehicle, recharge the lithium iron starting battery before installing it for use.

The two electrodes are disconnected and connected in the following order:

Disconnection: first negative electrode and then positive electrode;

Connection: first positive electrode and then negative electrode.

During the parking period, the vehicle shall be parked for 30 minutes every month to recharge the lithium iron starting battery. Check and maintain once every three months. If the terminal voltage of lithium iron starting battery is  $\geq 25.6$  V, it will be normal, otherwise, it shall be charged in time.

Before delivering the new vehicle to the user or starting a parked vehicle, the iron lithium starting battery shall be checked again for power loss. If the terminal voltage of the iron lithium starting battery is  $\geq 25.6$  V, it is considered normal. Otherwise, it shall be charged in time.

Lithium iron starting battery has low power protection function, and will automatically power off when the power is used to the reserved value of emergency starting power.



### Warning

---



**There is electrolyte inside the battery, which is harmful to people's skin and eyes. If the electrolyte touches your eyes, please do not rub it, rinse it with clear water immediately, and go to the hospital for treatment. If not handled properly, the electrolyte will harm your eyes!**

---

## 4. Maintenance of lithium iron starting battery

For routine maintenance, refer to the maintenance of battery in *Product Instruction Manual* of Weichai New Energy Commercial Vehicle Light-duty Truck.

### Front combination lamp

Properly adjust the front combination lamp to ensure that there is sufficient illumination when driving on the highway, and at the same time, the driver of the opposite vehicle will not feel dazzling. When adjusting the headlamps, it is best to contact the Company's Special Repair Station with special equipment.

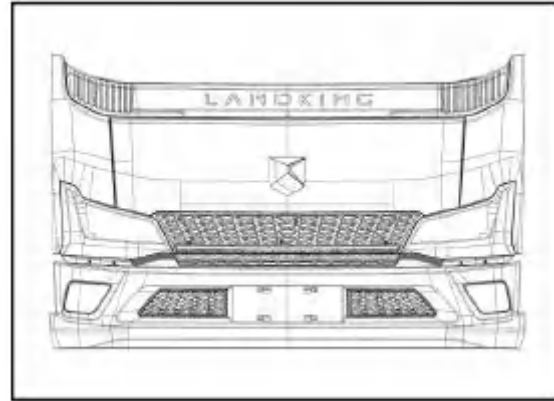

### Rear combination lamp

Remove the back cover of the combination lamp, and unscrew the combination lamp holder to replace the bulb.

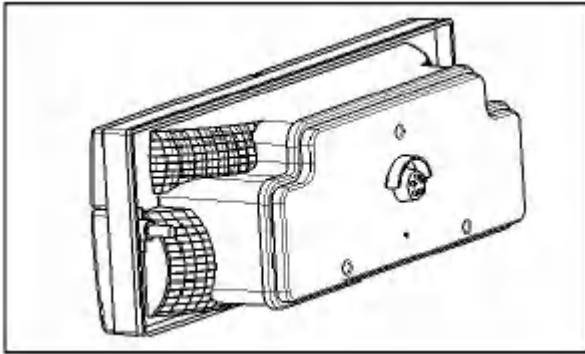

### **License plate light**

Unscrew the lampshade set screws, and remove the cover.

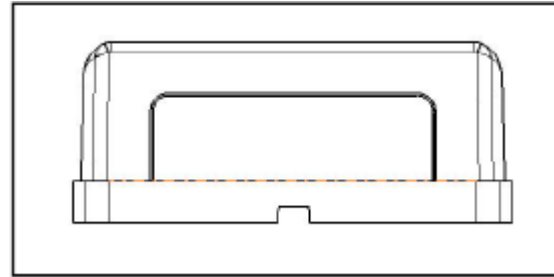

### **Indoor lighting**

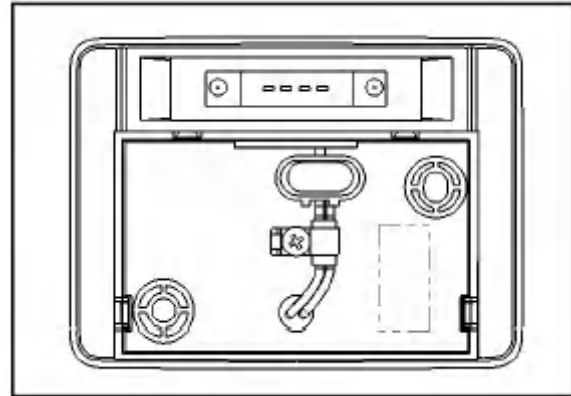

Unscrew the lampshade set screws, and remove the cover.

## Fuse box

1. The body fuse box is located below the Instrument panel toolbox, and the cover can be opened to check and replace fuses and relays.

2. The chassis fuse box is located behind the left front wheel. Open the fuse box cover to check and replace the fuse and relay. See the back label of the cover plate for the rated current value of the fuse and the name of the circuit used.

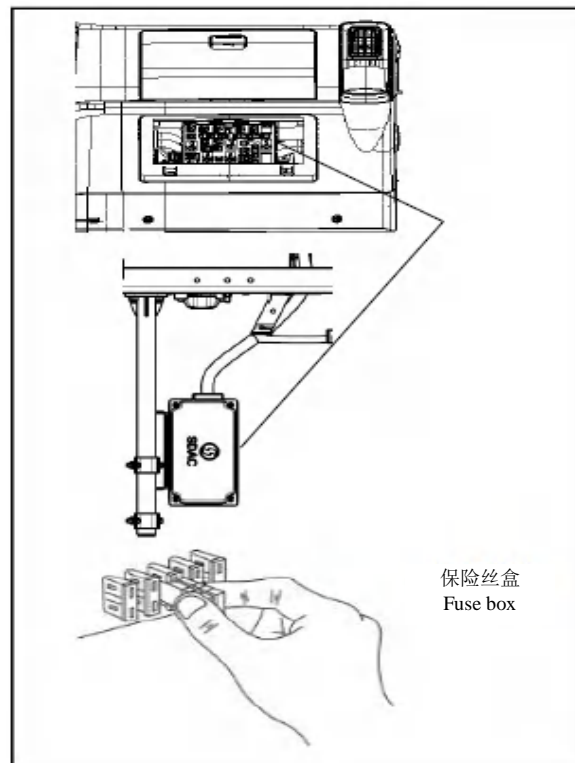

To replace the fuse, use the fuse remover.



### Danger

- When replacing, be sure to use regular brand fuses.
- Copper wire shall not be installed even as a temporary measure. It may cause more damage or even fire.
- Before replacing the fuse, be sure to check the cause of the fuse.



### Attention

- If the fuse is found to be blown, please check it by professionals to

find out the cause, and take necessary maintenance measures before replacing it.

- If the fuse is replaced, the ignition switch should be screwed to the "LOCK" position, and the fuse with the same current value must be used.

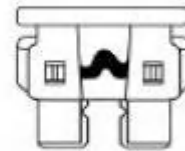

正常  
Normal

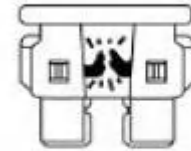

烧坏  
Burn out

# Lubrication

## Lubrication of vehicles

It is very important to select lubricating oil carefully according to the lubricating oil chart and viscosity according to ambient temperature. Please refer to the following chart and recommend using authentic series lubricating oil specially made by the Great Wall Lubricating Oil Branch of Sinopec and marked with the anti-counterfeiting logo of our Company.

Ambient temperature and viscosity diagram of gear oil for transmission and rear axle housing

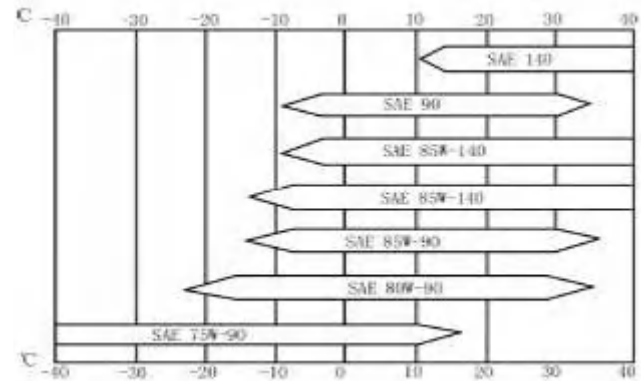

## Temperature and viscosity table of engine lubricating oil

Correspondence table between viscosity and ambient temperature			
Viscosity Grade	°C Use Temperature	Viscosity Grade	°C Use Temperature
SAE 75W-90	-30 to 10	SAE 80W-90	-10 to 10
SAE 85W-90	0 to 20	SAE 85W-140	10 to 30
SAE 90	20 to 30	SAE 140	30 to 40

	Range/ °C		Range/ °C
0W	-35~-15	10W~ 50	-25~50
0W~20	-35~20	15W~ 30	-20~30
0W~30	-35~30	15W~ 40	-20~40
0W~40	-35~40	15W~ 50	-20~50
5W	-30~-10	20W~ 30	-15~30
5W~20	-30~20	20W~ 40	-15~40
5W~30	-30~30	20W~ 50	-15~50
5W~40	-30~40	20	-10~20
5W~50	-30~50	30	-5~30
10W~	-25~30	40	5~40

30			
10W~ 40	-25~40	50	15~50
<p>Note: For the viscosity level of oils in the table, the smaller the number before W, the better the low-temperature performance of oils, and the larger the number after W, the greater the viscosity of oils. See GB 11122 for viscosity-temperature performance requirements of engine lubricating oil.</p>			

## Recommended grades of lubricating grease and fuel

In order to achieve the highest performance and the longest service life of your vehicle, it is extremely important to choose the appropriate grease and fuel according to the relevant charts. The lubrication cycle on the periodic maintenance interval schedule and the use of the new vehicle warranty period are based on the recommended lubricating grease. Recommended lubricating greases and fuels are shown in the following table, which shall be used as a guide for selecting appropriate levels and grades.

<b>Part</b>	<b>Recommended Grease</b>
Engine fuel	Adopt oil products corresponding to engine emission standards; 5# diesel oil is applicable to the minimum temperature more than 8 °C; 0# diesel oil is applicable to the minimum temperature more than 4 °C; -10# diesel oil is applicable to the minimum temperature more than -5 °C; -20# diesel oil is applicable to the minimum temperature more than -14 °C; -35# diesel oil is applicable to the minimum temperature more than -29 °C; -50# diesel oil is applicable to the minimum temperature more than -44 °C.
Engine lubricating fluid	CK-4 and above for National VI models.
Engine cooling system	Antifreeze (ethylene glycol).
Transmission	5J30T/5J38T/C6J45T/C6J50T/C6J55T/C6J75T/F6JZ45BM transmission lubricating oil grade: 80W/90 (GL-4) in summer and 75W/90 (GL-4) in winter.

	<p>8JS75T: 80W/90 (GL-5) 75W/90 (GL-5) 8JS75T transmission lubricating oil grade: 80W/90 (GL-5) in summer, 75W/90 (GL-5) in winter, medium load vehicle gear oil. 5J30T/5J38T/C6J45T/C6J50T/C6J55T/C6J75T/F6JZ45BM/8JS75T: FL-01E ( I 75W/90) 5J30T/5J38T/C6J45T/C6J50T/C6J55T/C6J75T/F6JZ45BM/8JS75T transmission lubricating oil grade (long-term oil): FL-01E (Shell &amp; Fast I 75W/90).</p>
--	---

	<b>Recommended Grease</b>
Transmission	It is strictly forbidden to use inferior lubricating oil, and different grades of lubricating oil cannot be mixed. You can refer to the ambient temperature and viscosity diagram of gear oil for transmission and rear axle housing, and choose them according to the local ambient temperature. It is strictly forbidden to use inferior lubricating oil, and different grades of lubricating oil cannot be mixed.
Rear axle and steering gear	Heavy duty gear oil GL-5, 80W/90 oil is applicable to minimum temperature of -26 °C; 85W/90 oil is applicable to minimum temperature of -12 °C; 90# oil is applicable to the minimum temperature more than 35 °C. Power steering fluid ATF-III-Q/SH038.501. HD-R04 HD-R04 for long-acting gear oil for the rear axle.
Clutch control system	V-3, DOT3 or HZY3 brake fluid.
Variable speed control mechanism	General Lithium grease for automobiles.
Front axle kingpin and front axle bearing	HP-R grease.
Universal joint, door lock, and window	Lithium grease No. 2.

regulator	
Battery electrode	Industrial Vaseline.
Windscreen washer	Room temperature: use water with hardness less than 205 g/1,000 kg. Low temperature ( $-20^{\circ}\text{C}\pm 3^{\circ}\text{C}$ ): use methanol aqueous solution with a volume concentration of 35%. Low temperature ( $-40^{\circ}\text{C}\pm 3^{\circ}\text{C}$ ): use methanol aqueous solution with a volume concentration of 50%.
Leaf spring pin	Lithium grease No. 2.

## Lubrication position figure

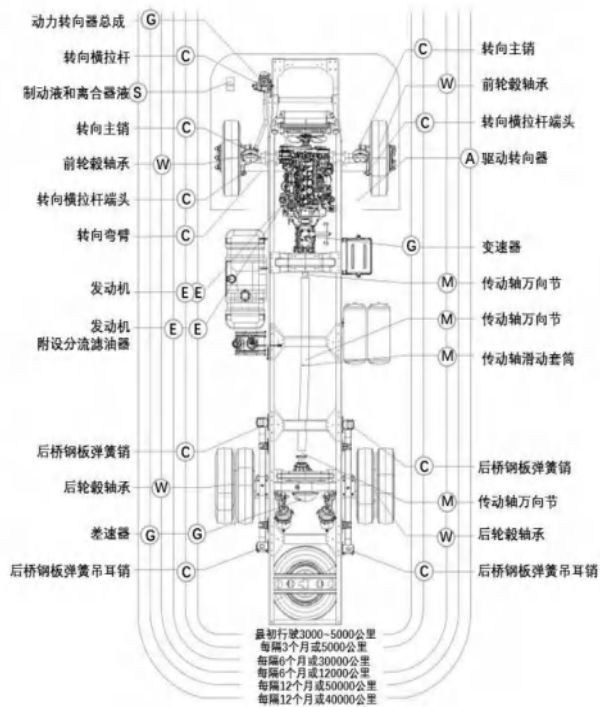

Lubrication position figure:

E: Engine

G: Gear oil

W: Wheel bearing lubricating oil

C: Multi-purpose lubricating oil

M: No. 2 lithium-based grease

S: Brake fluid

## Guide to lubrication

### Replacement of transmission oil

Unscrew the oil drain plug (D) of the transmission, inject the specified transmission gear oil into the transmission box from the oil filling hole (F) after draining the gear oil in the transmission, and fill it to the same height as the lower edge of the oil filling hole (F). It is advisable to overflow slightly from the oil filling hole.

5J38T transmission:

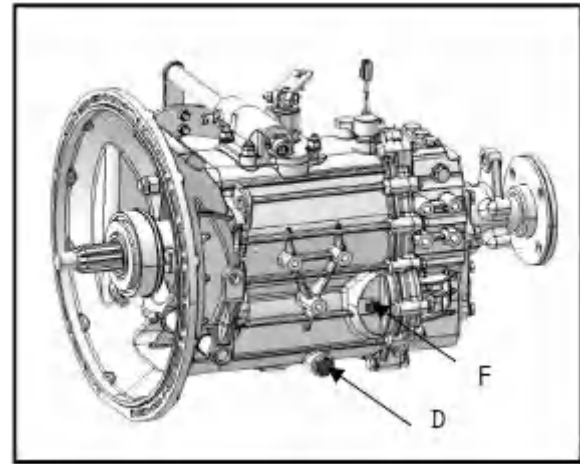

C6J45TB transmission:

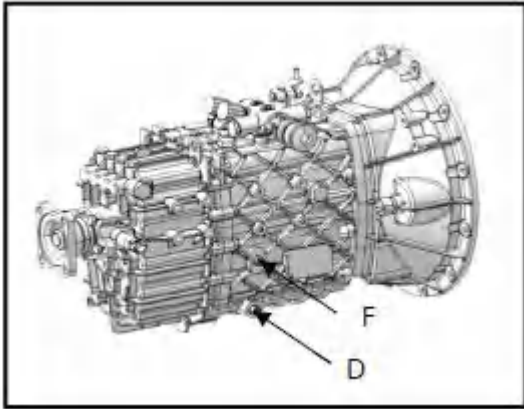

C6J50T/55T transmission:

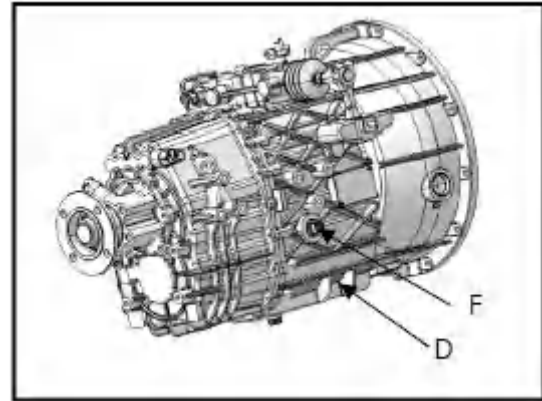

C6J75T transmission

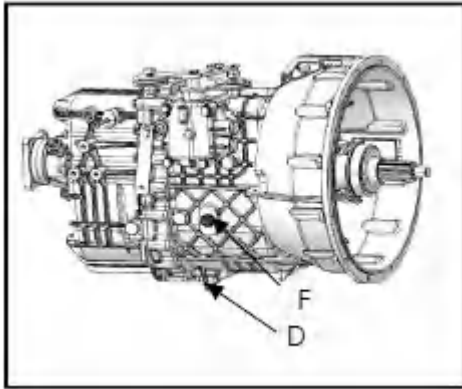

F6JZ45BM

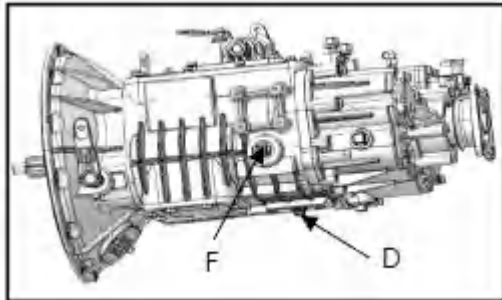

8JS75T transmission

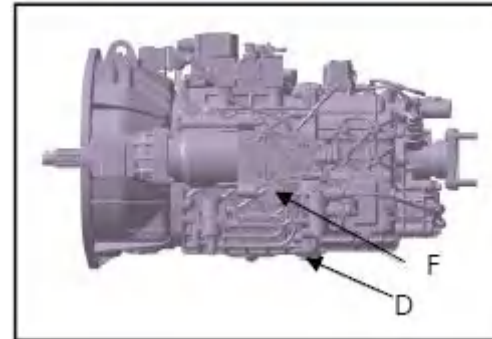

### Replacement of rear axle gear oil

Unscrew the oil drain plug (D) of the rear axle assembly, inject the specified gear oil into the rear axle assembly box from the oil filling hole (F) after draining the gear oil in the rear axle assembly, and fill it to the same height as the lower edge of the oil filling hole (F). It is advisable to overflow slightly from the oil filling hole.

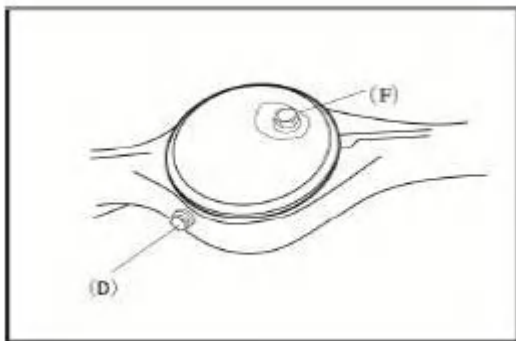

### **Replacement of grease on front and rear hub bearings**

If you need to replace the grease in hub bearings, because this operation needs to disassemble and reassemble the bearings, please contact our Special Repair Station.

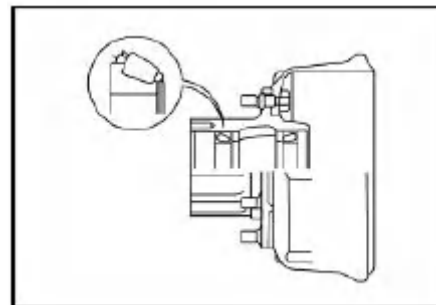

### **Lubricating position**

Please lubricate the steering kingpin (4 places) with HP-R grease.

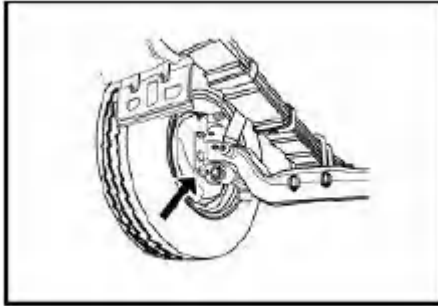

## Universal joint

Please lubricate the universal joint with grease containing No.2 lithium base.

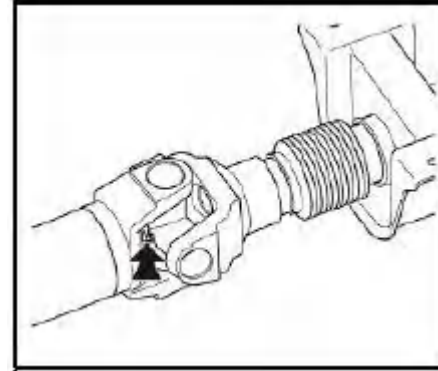

Intermediate support

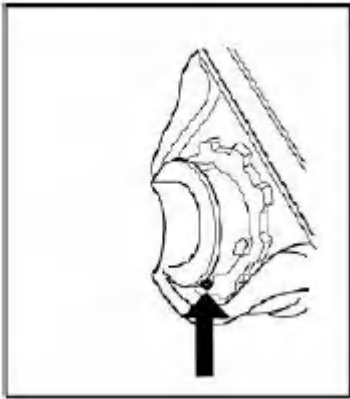

several times to completely drain the residual steering fluid in the hydraulic circuit. Install the removed hose securely, and inject the specified power steering fluid to the specified level of the steering tank. Start the engine at idle speed, turn the steering wheel left and right several times to exhaust (full range), and refuel into the steering tank at the same time, until the oil bubble is free when turning the steering wheel and the liquid level does not drop and reaches the specified liquid level (between the "MIN" and "MAX" lines depending on the engine temperature).

### **Power steering maintenance precautions**

When changing (refueling) oil of the steering gear, first support the front wheels so that they are completely off the ground. Remove the hose between the steering gear and the steering oil tank and that between the steering oil pump and the steering oil tank. After draining the steering fluid, turn the steering wheel to the left and right

Attention shall be paid to the use of steering gear:

 **Attention**

- **Add the liquid level to the requirements of the scale, and do**

**not add more, so as not to affect the exhaust effect.**

**Do not let foreign matter into the pipeline system, so as not to affect the performance of the steering system.**

① You should check whether the oil is clean and has impurities after the trial run of the new steering gear. Replace new oil, and clean the steering system if necessary.

② Check the oil level of the oil tank regularly, at least once every 5000 km.

③ After running-in of the new car, check the tightness of the connecting screws of each part of the steering system once.

When turning, stay the steering wheel in the steering limit position for no more than 5s to avoid damaging the steering system.

Please check and tighten all kinds of bolts in the hopper regularly.

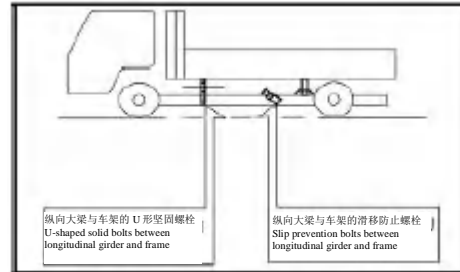

			1
	6		6

## Loading method

## Loading method

### 1 Loading restrictions

① Keep the width of the goods not exceeds the hopper.

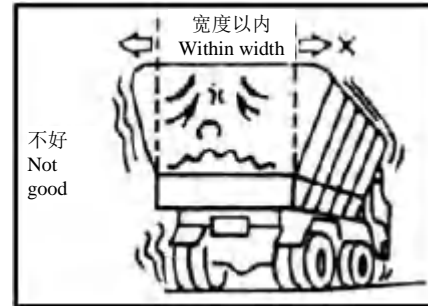

② Try not to make the goods protrude from the back of the vehicle.

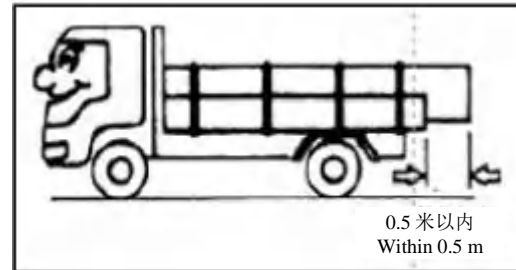

## 2 Loading instances

① Gently open and close the hopper, rough operation will shorten its service life.

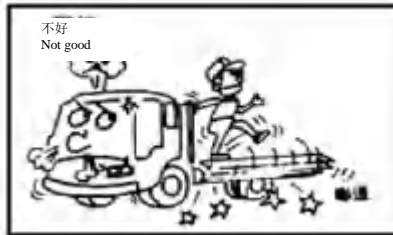
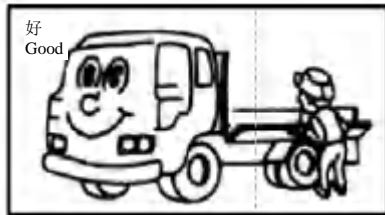

② Handle carefully. Throwing goods will damage the goods and the hopper.

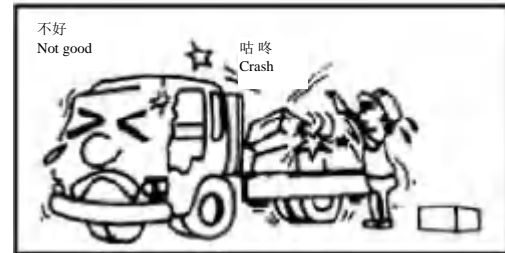

③ Tie the goods tightly with ropes. If it is not fixed properly, the materials will be scattered during driving.

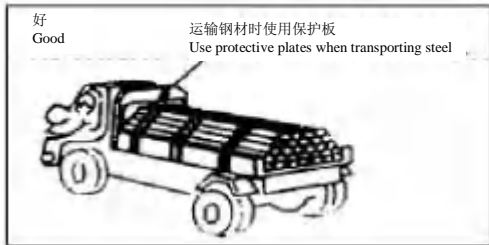
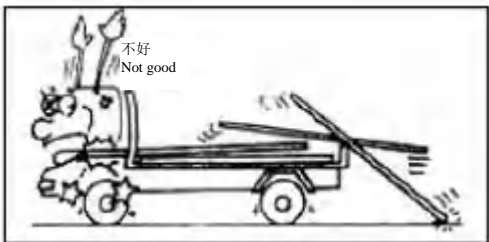
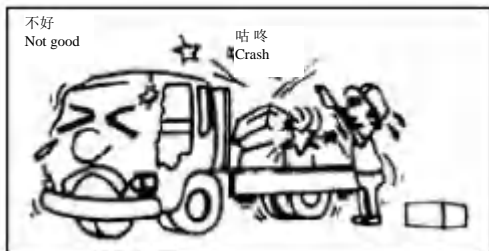

④ Load the goods low and evenly. Unbalanced load will not only make driving unstable, but also damage goods and hoppers. Fix tall goods at the center of the hopper.

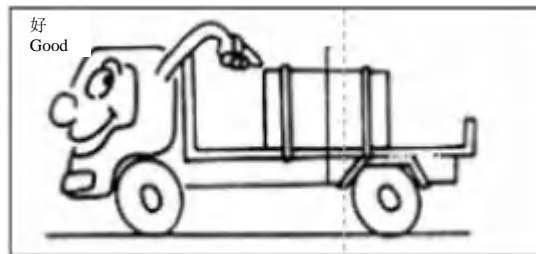
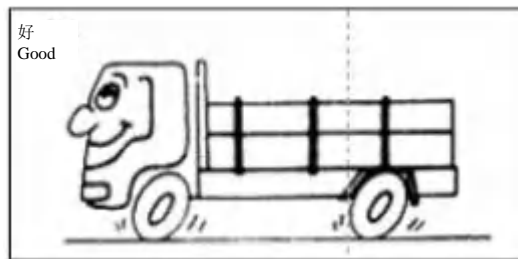

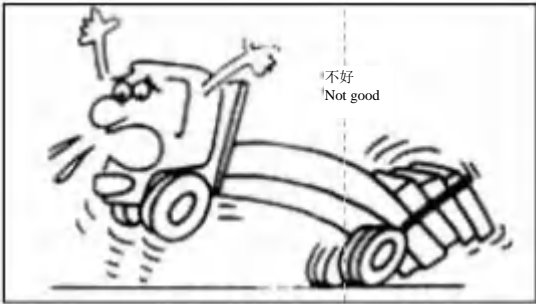
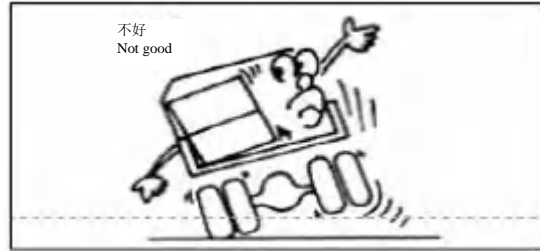
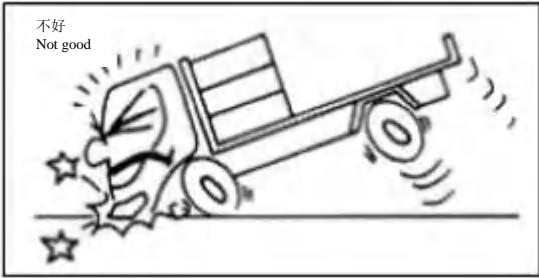

⑤ For long goods, use shelves, which shall be counted as a part of the goods. If they are supported only by the front frame and back door, the hopper is easy to deform due to uneven stress.

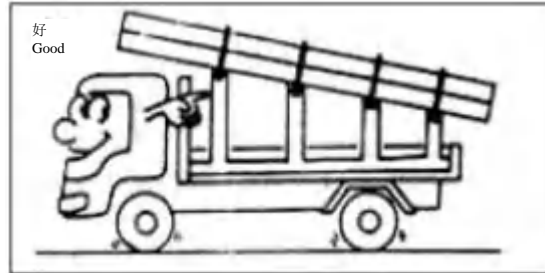

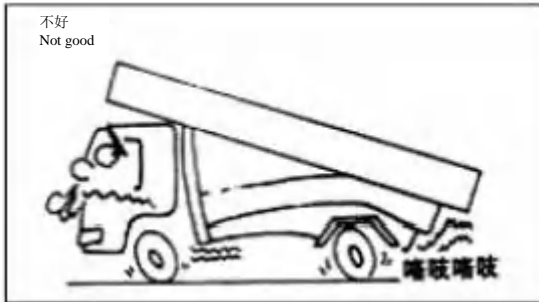

### Attention

- The height limit of vehicles shall give priority to the restrictions of laws and regulations.

- The loading mode using the rack has the possibility of turning over because the center of gravity of the vehicle becomes higher, so please

pay full attention to avoiding high-speed mode, sharp braking, and sharp steering when driving.

⑥ Take measures to disperse goods with concentrated weight, and steel plates or sleepers shall be counted as part of the goods. If no measures are taken, the bottom of the hopper will be damaged.

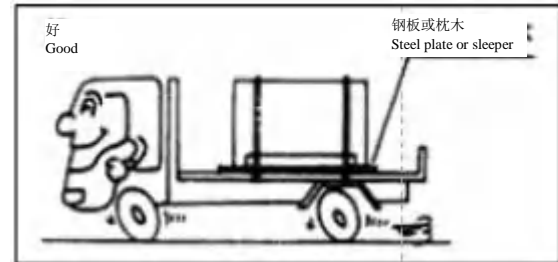

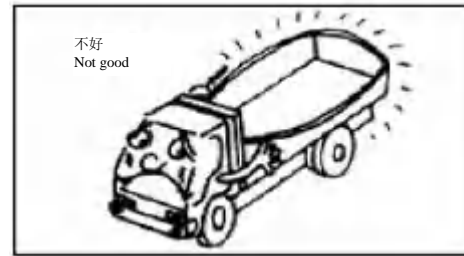
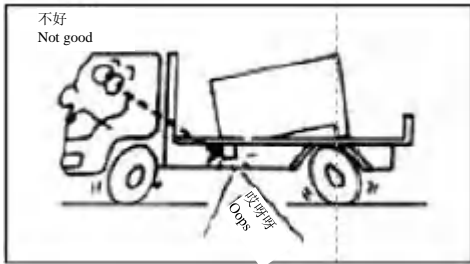

⑦ When transporting bulk goods, tighten the side plates from both sides. If they are not tightened, the hopper may be deformed.

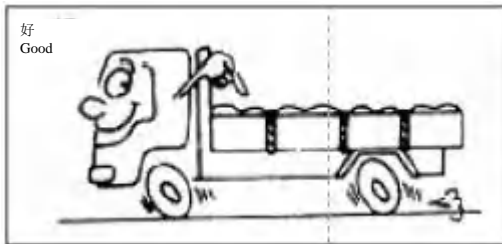

⑧ When pulling, use the towing hook on the frame, and never use the hopper for traction.

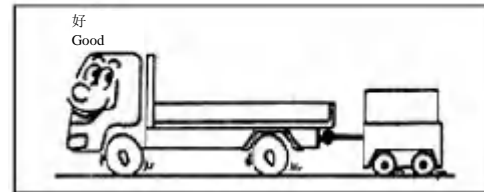

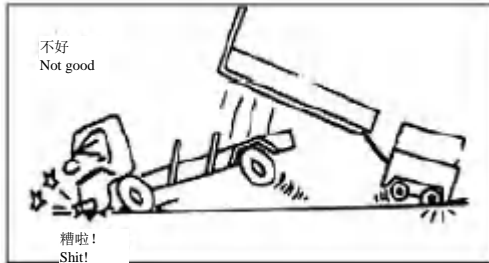

## Main data and specifications

### Main data and specifications

Main data of engine (subject to actual nameplate)

Model	WP2.3NQ130E61	WP2.5NQ150E61	WP2.5NQ160E61	WP3NQ160E61	WP3NQ170E62
Type	Four-cylinder, in-line, water-cooling, direct injection, and diesel engine				
Rated power/speed (kW/r/min)	96/3200	110/2900	118/2900	118/3000	125/2800
Maximum torque/speed (N.m/rpm)	380/1600~2400	400/1400~2200	450/1400~2200	480/1400~2200	520/1400~2100
Maximum net power/speed	92/3200	106/2900	114/2900	114/3000	121/2800
Total displacement (L)	2.289	2.49	2.49	2.97	2.97
Compression ratio	17.1±0.5:1			(16.8±0.8) :1	
Net mass (kg)	230	240	240	290	280
Idle speed (r/min)	750			700	
Engine oil capacity (L)	7~8	10	10	7~8	7~8
Emission level	National VI				

## Main data and specifications

Vehicle type		K5000
Vehicle wheelbase		3300
Length * width * height (mm)		See Vehicle Conformity Certificate
Overall mass (kg)		See Vehicle Conformity Certificate
Maximum permissible mass (kg)		See Vehicle Conformity Certificate
Vehicle fuel consumption under specified test conditions (L/100 km)		11.4
Maximum design speed (full load) km/h		See Vehicle Conformity Certificate
Driving type		Front engine rear drive
Front wheel alignment parameters	Toe-in (mm)	1~4
	Wheel camber (°)	0.5~1.5
	Kingpin caster (°)	2.5~4.5
	Kingpin inclination (°)	6.5~7.5
Travel braking system	Type	Pneumatic drum double-circuit wheel brake, front disc rear drum double-circuit wheel brake
	Pedal free stroke (mm)	10~15
	Rated working pressure of air	850kpa

	reservoir		
	Initial pressure		510kpa
	Response time A from depressing the brake pedal to the most unfavorable brake chamber		0.6s
Parking brake system	Type		Air brake
Auxiliary braking system	Type		Exhaust brake
Brake force adjustment type			Brake clearance self-adjusting arm, brake clearance manual adjusting arm
Suspension device	Front	Type	Longitudinal, elliptical leaf spring, non-independent suspension, hydraulic two-way bucket shock absorber
		Number of leaf spring	13791011
	Rear	Type	Longitudinal, elliptical leaf spring, non-independent suspension, hydraulic two-way bucket shock absorber
		Number of leaf spring	1+13+25+38+69+79+810+10
			The rear protection connection mode is bolted with the longitudinal beam of the frame, and the material of the rear lower protection device is

Technical requirements for side protection and rear lower protection		Q345A/B1500HS/aluminium alloy 6061-T6. Cross-sectional dimension of the rear protective device is 100 mm × 50 mm.
		The side protection connection mode is bolted with the container beam, and the material is formed by Q235A steel plate or aluminum alloy profile. The height of Q235 steel plate guardrail is 125 mm, and the height of aluminum alloy guardrail is 100 mm.
(kg) Permissible value of axle load (kg)	Front axle	16101795184018901900
	Rear axle	28852600265526052595
Max. gradeability		≥30%

## Main data and specifications

		Model	5J30T-B	5J38T	F6JZ45BM	C6J45TB	C6J50T	C6J70T	8JS75T	
<b>Transmission</b>	Type	Mechanical, five forward gears, one reverse gear, with full synchronizer			Mechanical, six forward gears, one reverse gear, with full synchronizer				Mechanical, eight forward gears, one reverse gear, with full synchronizer	
	Control mode	Flexible shaft remote control			Electronic controller	Flexible shaft remote control				
	Speed ratio	5J30T-B	i1:5.61i2:3.08i3:1.74i4:1.00i5:0.80iR:5.14							
		5J38T	i1:5.50i2:3.08i3:1.74i4:1.00i5:0.80iR:4.89							
		F6JZ45BM	i1:6.15i2:3.36i3:2.03i4:1.37i5:1.00i6:0.8iR:5.57							
		C6J45TB	i1:6.15i2:3.36i3:2.03i4:1.37i5:1.00i6:0.8iR:5.57							
		C6J50T	i1:6.18i2:3.33i3:2.08i4:1.40i5:1.00i6:0.78iR:5.57							
		C6J70T	i1:6.09i2:3.34i3:2.07i4:1.40i5:1.00i6:0.79iR:5.55							
8JS75T	i1:7.34i2:5.24i3:3.76i4:2.82i5:1.95i6:1.39i7:1.00i8:0.75iR:7.34									
Rear axle	Type	Integral pipa type, press-welding axle housing								
	Main transmission ratio	3.73.94.1114.3334.8755.1255.286								

## Main data and specifications

Steering mechanism	Steering gear specification	80 bore	85 bore	90 cylinder bore	100 cylinder bore
	Steering gear type	Recirculating ball type			
	Steering wheel free stroke (°)	±7.5			
	Steering booster oil filling (L)	1.5		1.7	
Clutch	Diameter (mm)	Φ310 Φ325			
	Type	Single dry diaphragm spring			
	Pedal free stroke (mm)	10~15			

# Instructions on the measurement of vehicle overall dimensions

## Devices that are not in the measurement range

According to the provisions on the measurement of overall dimensions in *Limits of Dimensions, Axle Load and Masses for Motor Vehicles, Trailers and Combination Vehicles (GB1589)*, the following devices are not within the measurement range of overall dimensions of the whole vehicle.

### 1 Measurement of length

1.1 The following devices that do not have a cargo loading function and exceed the front or rear end of the vehicle by no more than 50 mm, and the fillet radius of the edges and corners by no less than 5 mm are not within the vehicle length measurement range:



Wiper and washer;



External signs, including registered commodity trademarks, names of production enterprises, commodity origin, vehicle name and model, engine displacement, transmission type, driving type, and other signs reflecting vehicle characteristics;



Light and light signal devices;



Anti-collision rubber blocks and similar devices;



External sunshade device;



Customs sealing devices and their protective devices;



Devices for bolting rain-proof cloth and their protective devices;



Locking device, hinge, handle, controller, and switch;



Entrance and exit steps (or ladder climbing), and boarding steps and handles at the upper end of the bumper for wiping wind windows;



LOGO

Rear sign board contained LOGO;



Detachable hitching or towing devices for vehicles;



Exhaust tail pipe.

1.2 The following devices that do not have cargo loading function are not within the vehicle length measurement range:



Air intake pipe;



Refrigerator of the refrigerated semi-trailer within its front slewing radius, tool kit frame of the semi-trailer, climbing ladder, front air/electrical connector, and shield thereof;



Indirect visual field device;



Current collecting equipment of electric vehicle (including its fixing device)



2000mm200mm

Removable or foldable rear guiding device of the vehicle with unfolded length not exceeding 2,000 mm and retracted state not exceeding 200 mm;



300mm

Tail plates, up and down ramps, and similar devices with a horizontal length not exceeding 300 mm in the retracted state;



Rear tail ladder.

## **2 Width measurement**

2.1 The following devices that do not have cargo loading function, and one side exceeds the side of the vehicle by no more than 50 mm, and the fillet radius of the side and corner by no less than 5 mm are not within the vehicle width measurement range;



External signs, including registered commodity trademarks, names of production enterprises, commodity origin, vehicle name and model, engine displacement, gearbox type, driving type, and other signs reflecting vehicle characteristics;



Light and light signal devices;



Customs sealing devices and their protective devices;



Anti-collision tape and similar devices;



Devices for bolting rain-proof cloth and their protective devices;



Local water channel: Refers to the water channel used to guide rainwater flow above the driver's door (or window), above the passenger door, and on both sides of the front windshield glass to guide rainwater flow;



Flexible protrusion of anti-splash system;



Telescopic steps in the retracted position, access ramps of passenger cars, lifting platforms, and similar devices;



Locking device, hinge, handle, controller, and switch;



Tire failure signal device;



Tire pressure indicator;



Deformed part of the tire wall directly above the tire grounding point;



Reversing auxiliary device;



Exhaust tail pipe.

2.2 The following devices are outside the vehicle width measurement range:



Indirect visual field device;



School bus stop sign in non-working state.

### **3 Height measurement**



Device out of measurement range: soft parts of the antenna.